



METAL PRODUCTS
(800) 705-4550

Table of Contents

	<u>Page</u>
General Information	2-6
General Terms and Conditions	2-5
Color Line	6
Panels & Trim	7-47
PBRECO4 Panel	7-13
ECORIB5 5 Panel	14-24
2½ CORRUGATED Panel	25-35
ECOLOCK Panel	36-41
Edge Flashings	42-47
Fasteners/Screws	48-50
Polycarbonate Panels	51
Doors & Windows	52-57
Accessories	58-63
Closures	59
Cupolas	60
Flex Seal	60
Insulation	61
Panel Profile Vents	61
Pipe Flashing	62
Roll Valleys	63
Sealants & Tape	63
Touch-up Paint	63
Underlayment	63
Framing Components	64-78
Base Plates & Tubing	64
Trusses	65-68
Sub-components	69-70
Hat Channel	71
C-Purlins and Track	72-73
Brackets	74-78
Pricing	



METAL PRODUCTS
(800) 705-4550

General Terms and Conditions of Sale

ALL ORDERS, OFFERS, ACCEPTANCES, CONFIRMATIONS, CONTRACTS, SHIPMENTS OR SALES RELATING TO THIS TRANSACTION INCLUDE AND ARE SUBJECT TO THE FOLLOWING GENERAL TERMS AND CONDITIONS OF SALE BETWEEN **AFP METAL PRODUCTS** (HEREINAFTER "SELLER") AND THE **CUSTOMER** (HEREINAFTER "BUYER").

PRICE DATA

1. All prices and delivery terms are subject to change without prior notice. All goods will be invoiced at price in effect at time of shipment, whether or not Buyer is in possession of a price book or price sheet reflecting prices different than in effect at time of shipment and not withstanding prior quotations and/or acknowledgements with a different price.
2. Any tax or other government charge upon production, sale or shipment of goods imposed by Federal, State or Municipal authorities shall be charged to and paid by the Buyer in addition to the purchase price.
3. All prices are F.O.B. Seller's point of shipment unless otherwise specified. Upon due tender of the goods for delivery at the F.O.B. point, all risks or loss or damage to Buyer, regardless of terms of payment or form of bill of lading, or the mode of shipment, or who pays the actual transportation charges.
4. All prices cover only material considered by the Seller as commercial with regard to tolerances, sizes, finishes, properties and domestic packaging.

VERBAL ORDERS

5. Buyer assumes responsibility for the accuracy of verbal orders unless written confirmation is received prior to fabrication. Confirming orders must be marked "confirming order—do not duplicate".

PAYMENT AND CREDIT TERMS

6. Net Cash thirty (30) days from date of invoice, subject to approval of the treasurer, unless otherwise specified.
7. Seller may refuse, change or withdraw extensions of credit at any time in its sole discretion. Seller shall have the right to demand payment on delivery of the goods or prior to shipment of the goods to the extent it deems advisable, to refuse, change or withdraw extensions of credit.
8. Produced orders may be shipped and invoiced after 4 weeks have elapsed.

WARRANTY OR GUARANTY AND REMEDIES

9. Seller warrants that title to the products conveyed shall be free of any encumbrances. Seller's products sold hereunder are guaranteed for a period of ninety (90) days from the date of delivery to the Buyer to be free of defects in material and workmanship.
10. Any claim on account of a defect in the product or for any other cause whatsoever shall be deemed WAIVED by Buyer unless written notice thereof is given to Seller within ninety (90) days after delivery. Seller shall be given reasonable opportunity to investigate all claims and no products shall be returned to Seller until after inspection and approval by Seller and receipt by Buyer of written shipping instructions from seller.
11. If it is determined to Seller's reasonable satisfaction, upon inspection, that a product is defective, Seller shall have the right to either repair or replace such product, to refund the purchase price upon return of such product, or to grant a reasonable allowance on account of such defect. Seller's liability and Buyer's exclusive remedy under this warranty or guaranty shall be limited to replacement, repair, refund, or allowance, as Seller may elect.
12. This guaranty or warranty is IN LIEU OF and EXCLUDES all other warranties, expressed or implied by operation of law or otherwise including any warranty of MERCHANTABILITY or that the goods can be used FOR ANY PARTICULAR PURPOSE desired by Buyer. Seller DISCLAIMS and Buyer WAIVES all remedies not provided herein including any liability of Seller in tort, strict or otherwise, for damages or injuries to persons or property, or for loss of use, revenue or profit, whether direct, incidental or consequential, resulting from any defect in design, material, workmanship or manufacture, whether or not caused by negligence on the part of the Seller. Oral statements made by Seller's representatives about the products and written descriptions of the products appearing elsewhere than on the face hereof are not warranties and shall not be relied upon by Buyer. This writing constitutes the final, complete, and exclusive expression of the terms of the parties' agreement.



METAL PRODUCTS
(800) 705-4550

**General Terms and
Conditions of Sale**

TRANSFERS, ASSIGNMENTS AND REPRESENTATIONS

13. This guaranty or warranty is extended to Buyer as the original purchaser from Seller and is non-transferable and non-assignable. No rights against Seller shall be created by any transfer or assignment, nor shall any rights against Seller survive any transfer or assignment. Buyer or its agents or representatives shall not claim, represent or imply nor permit its customers, distributors, applicators or contractors to claim represent or imply that this guaranty or warranty extends or is available to parties other than Buyer, and to the limit of its legal right to do so Buyer shall cause any party to cease and desist of any such misrepresentation. This condition shall constitute a material term of this guaranty or warranty and its violation by Buyer shall excuse Seller from its obligations hereunder.

DELAY

14. Seller shall be excused for any delay in deliveries due to acts beyond its control and not due to its fault or negligence, including but not restricted to acts of God, or of the Public Enemy; acts of government of the United States (including but not in limitation thereof, any preference, priority or allocation order) or of any state, territory, or possession thereof, or of any political sub-division of authority or representatives of any of them, strikes, lock-outs, or labor troubles; embargoes, fires, floods, epidemics, quarantine restrictions, failure of delivery of materials to Seller, explosions, sabotage, or other catastrophes or serious accidents, freight embargoes, unusually severe weather and delays of a supplier of material or of a sub-contractor due to any of such causes. Seller may, at its option, cancel this order, or delay performance hereunder for any period reasonably necessary due to any of the foregoing, during which time this agreement shall remain in full force and effect. Seller shall have the further right to then allocate its available materials and products between its own end uses and its customers in such manner as Seller may consider equitable.

DEFAULT

15. Each shipment hereunder shall be deemed a separate contract and if Buyer fails to pay any invoice when due, or fails to accept any shipment as scheduled, Seller may, without prejudice to other remedies, either defer further shipment until the default is corrected or cancel the unfilled portion of this order and of any or all other orders. Seller's waiver of any provisions herein or any breach thereof shall not constitute a waiver of any subsequent breach nor of any other provision herein.

RESTOCKING CHARGES

16. In the event an order is canceled or changed by the Buyer after manufacture or production, Buyer shall pay to Seller a fee equal to 15% (fifteen percent) of the agreed to price for goods and services ordered. Such fee shall be in particular consideration for Seller's processing and handling of the order and restocking expense and shall not be construed as liquidated damages. This shall be in addition to all other remedies Seller may have under applicable law by reason of any such cancellation by Buyer. In the event an order for a custom color or lengths is canceled by the Buyer after manufactured or produced, Buyer shall pay to Seller a fee equal to 100% of the agreed to price.

INTEREST CHARGES

17. In the event that an order is delayed for 60 (sixty) days or more beyond the original scheduled release date, the Buyer shall pay to Seller 1% (one) of the material sale price for each additional 30-day delay period. Such fee will be in particular consideration for Seller's inventory carrying charges and shall not be construed as liquidated and shall be in addition to all other remedies Seller may have under applicable law by reason of any such delays or cancellations by Buyer.

SPECIAL TOOL CHARGES

18. Any equipment provided by Seller for use in production of products for Buyer shall be Seller's property. Seller shall have no liability for loss or damage of any material or equipment provided by Buyer, and if for 3 (three) years Buyer does not order products manufactured with any such materials or equipment, Seller shall be free to dispose thereof.



METAL PRODUCTS
(800) 705-4550

General Terms and Conditions of Sale

TOLERANCES

19. Tolerances will be in accordance with Seller's published standards in effect on the date of order or any then applicable industry standards for the goods if Seller has no published standards.

JURISDICTION

20. Any contracts arising out of Buyer's order shall be governed as to all matters affecting its validity, construction or performance per the laws of the State of California.

ENTIRE AGREEMENT

21. The terms and conditions of any contract arising from Buyer's order are these GENERAL TERMS AND CONDITIONS OF SALE which cannot be expanded or altered in any manner except in writing signed by both Buyer and Seller.

WHITTIER, CALIFORNIA

GENERAL PRICING NOTES

1. Cutting charges may apply—see profile sheet.
2. Prices apply to quantities ordered by projects for production at one time with shipment to one destination. Pricing for new orders will be based on the quantity of the order. Additions to existing orders which can be produced with the original order can be combined for appropriate bracket pricing.
3. Quotations are based on all quantities noted for all items and does not apply for lesser quantities or if order does not include all items noted.
4. Non-stock or special project materials will be ordered based on the customer's purchase order quantities. When the actual cut list requirements are less than the customer's estimated quantities by 3% or more, excess product will be charged back to the customer's account.

FREIGHT TERMS

1. Quotations are applicable for panel lengths less than 40' 0".
2. All panel lengths exceeding 40' 0" are subject to special freight quotation conditions and rates.
3. All product/panel lengths exceeding 25' 1" must be shipped as, and subject to T/L (truckload) rates.
4. Weight per skid is AFP Metal Products option. Normal skid weights are 2,000 lbs to 4,000 lbs, but may vary by product, length and order quantity.
5. All accessory items (I.e. fasteners, closures, sealants, etc.) shipped alone will be sold FOB shipping point with no freight allowed.
6. All stop-offs in transit will be invoiced to the Buyer.
7. Total quantity of truckloads required is dependent upon panel profile, panel lengths and accessory items required.
8. The customer will be charged \$200.00 for all jobsite deliveries within a 75 mile radius of the plant. If outside of the 75 mile radius the customer will be charged \$250.00 + \$2.50/mile.



METAL PRODUCTS
(800) 705-4550

**General Terms and
Conditions of Sale**

WHITTIER, CALIFORNIA

FREIGHT CONDITIONS

1. The agency method and routing will be designated by AFP Metal Products. Any excess transportation costs (other than the lowest published truckload rate) shipping or packing, designated by the Buyer, where customer of the shipment is taken shall be the Buyer's expense. If the Buyer picks up products in a vehicle under his control, Buyer's vehicle becomes the destination.
2. Upon due tender of products at the FOB point, all risk of loss or damage or other incidents of ownership pass to the Buyer, but seller retains a security in the products until the purchase price is paid.
3. Special packaging requests will be subject to additional charges.

GENERAL NOTES

1. Oil canning is not considered cause for rejection.
2. Buyer assumes responsibility for the accuracy of verbal orders unless written confirmation is received prior to fabrication. Confirming order must be marked "Confirming order—do not duplicate". Verbal orders which purport to state terms and conditions in addition to AFP Metal Products written terms and conditions stated herein, are deemed rejected and void unless agreed to in writing by AFP Metal Products prior to shipment of goods.
3. Due to product improvements, changes and other factors, AFP Metal Products reserves the right to change or delete information herein without prior notice or obligation to make changes in products previously purchased.

NOTES:

1. Product is defined as being steel roofing, siding, fascia and soffit of the same finish, gauge and configuration. Only length may vary.
2. A "square" is defined as 100 square feet of sheet based on overall width and length.
3. Steel is defined as galvanized or galvalume steel (bare or painted).
4. Destination is limited to within the continental United States excluding Alaska and Hawaii. All other destinations and/or freight charges are subject to inquiry.
5. Some panels are manufactured with stiffener ribs in the flat areas to minimize oil canning. However, due to the limitations of commercially available metals, some oil canning should be anticipated. Any oil canning experienced in AFP Metal Products will not be considered cause for rejection.



METAL PRODUCTS
(800) 705-4550

AFP Color Line & Codes
For Panel & Trim

AFP Metal Products Color Line

<u>COLOR</u>	<u>Code</u>	<u>COLOR</u>	<u>Code</u>
Terra Cotta	214	Country Red	231
China White	217	Emerald Green	232
Old Town Gray	218	Bright White	233
Light Stone	220	Hawaiian Blue	234
Polar White	221	Patina Green	235
Sahara Tan	222	Ash Gray	236
Tahoe Blue	224	Burgundy	272
Denali Green	225	Copper Penny	337
Sea Wolf	226	Brownstone	546
Charcoal	227	Vintage Copper	552
Burnished Slate	228	Galvanized	G
Cocoa	229	Galvalume	Z
Ivory	230		

CUSTOM TRIM PRICING FORMULA IS AS FOLLOWS

INCHES IN WIDTH + NUMBER OF BENDS X Price Factor
(see factor on your pricing sheet) = price per 10' 6" piece 29 gauge painted.
Call for pricing on other gauges and bare. Hems count as 2 bends.



METAL PRODUCTS
(800) 705-4550

PBRECO4
Panel

PBRECO4
Panel Profile
Part # PB6-XXX
(XXX = Color Code)

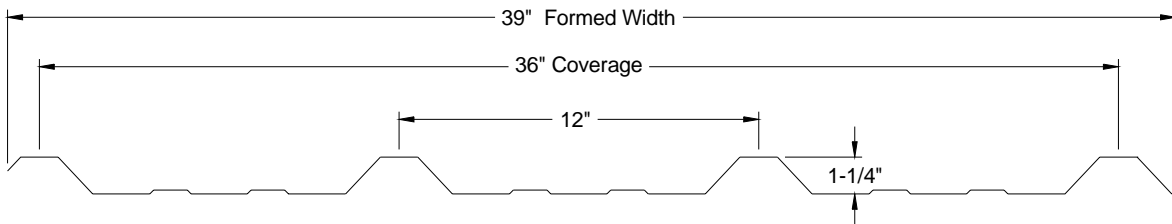

COLOR AVAILABILITY
DURA COAT XT-40S CERANAMEL

<u>COLOR</u>	<u>Code</u>	<u>COLOR</u>	<u>Code</u>	<u>COLOR</u>	<u>Code</u>
China White	217	Terra Cotta	214	Burgundy	272
Bright White	233	Country Red	231	Hawaiian Blue	234
Polar White	221	Cocoa Brown	229	Tahoe Blue	224
Ivory	230	Ash Gray	236	Patina Green	235
Light Stone	220	Old Town Gray	218	Denali Green	225
Sea Wolf	226	Charcoal	227	Emerald Green	232
Sahara Tan	222	Burnished Slate	228	Copper Penny	337
Brownstone	546	Vintage Copper	552	Galvanized (bare)	G
				Galvalume (bare)	Z

NOTES:

- 1.) General Terms and Conditions of Sale will apply to all sales.
- 2.) All formed sheets will be invoiced on a per L/F basis.
- 3.) Maximum standard length per formed sheet is 40'.
 Call for pricing and lead times on longer lengths



METAL PRODUCTS
(800) 705-4550

PBRECO4
XXX = Color Code (p. 7)

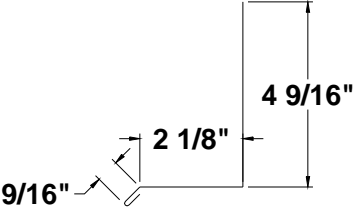
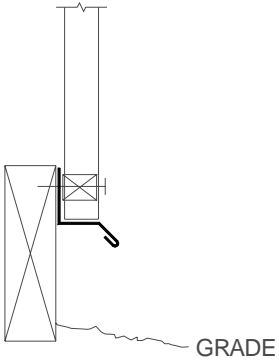
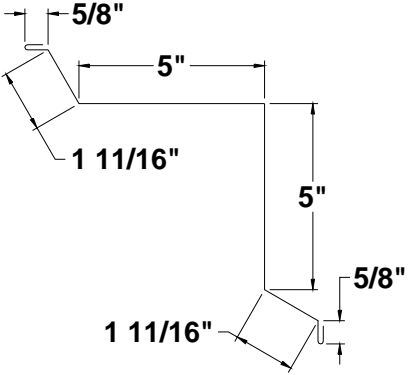
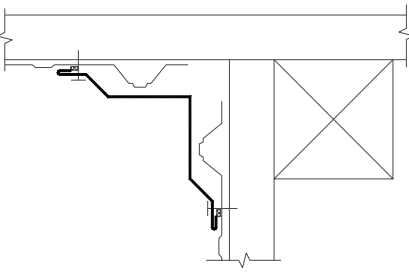
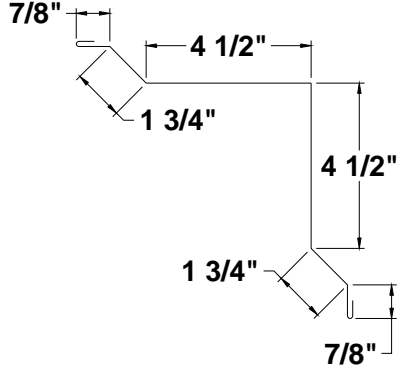
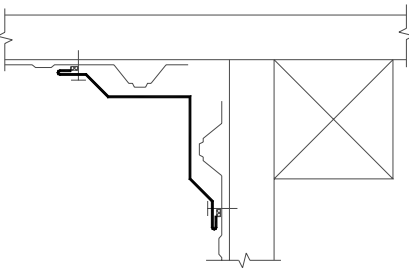
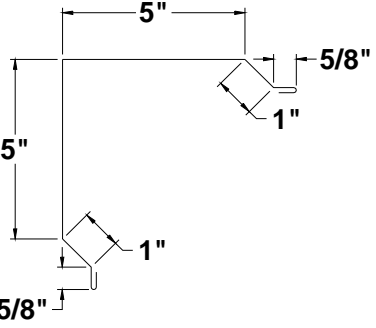
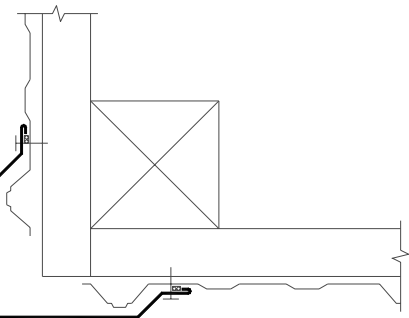
	<p>Base Angle / Sill Trim</p> <p><u>TBBA-1-XXX</u></p> <p>10' 6"</p>	
	<p>Corner—Inside 1</p> <p><u>TBIC-1-XXX</u></p> <p>10' 6"</p>	
	<p>Corner—Inside 2</p> <p><u>TBIC-2-XXX</u></p> <p>10' 6"</p>	
	<p>Corner— Outside 1</p> <p><u>TBOC-1XXX</u></p> <p>10' 6"</p>	



METAL PRODUCTS
(800) 705-4550

PBRECO4
XXX = Color Code (p. 7)

	<p>Corner- Outside 2 <u>TBOC-2-XXX</u> 10' 6"</p>	
	<p>Eave Flashing <u>TBEF-1-XXX</u> 10' 6"</p>	
	<p>Fascia / Jamb 3.5 <u>TAF-3.5-XXX</u> 10' 6"</p>	
	<p>Fascia / Jamb 5.5 <u>TAF-5.5-XXX</u> 10' 6"</p>	
	<p>Fascia / Jamb 7.5 <u>TAF-7.5-XXX</u> 10' 6"</p>	
	<p>Fascia / Jamb 9.5 <u>TAF-9.5-XXX</u> 10' 6"</p>	



METAL PRODUCTS
(800) 705-4550

PBRECO4
XXX = Color Code (p. 7)

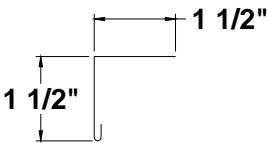
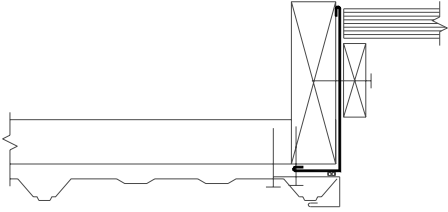
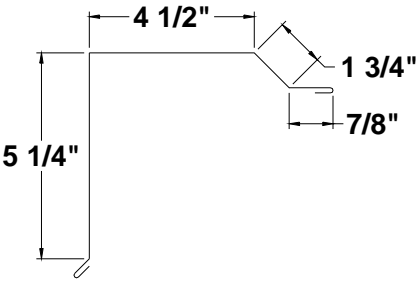
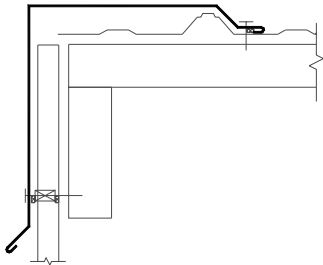
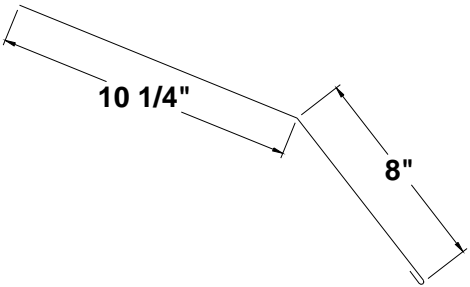
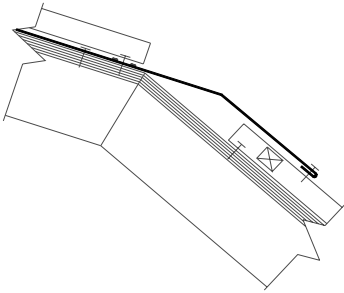
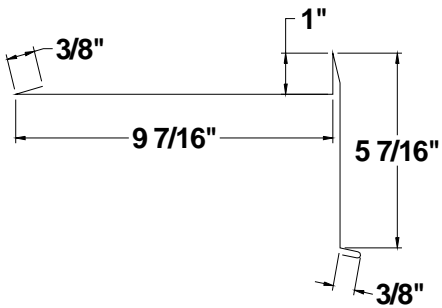
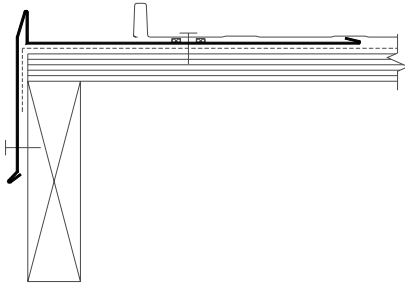
	<p>Fascia / Jamb 1.5 <u>TAF-1.5-XXX</u> 10' 6"</p>	
	<p>Gable Flashing <u>TBGF-1-XXX</u> 10' 6"</p>	
	<p>Gambrel / Slope Transition <u>TBGT-1-XXX</u> 10' 6"</p>	
	<p>Gable Trim— Swept Wing <u>TDGSW-1-XXX</u> 10' 6"</p>	



METAL PRODUCTS
(800) 705-4550

PBRECO4
XXX = Color Code (p. 7)

	<p>Head & Curb Flashing <u>TBHCF-1-XXX</u> 10' 6"</p>	
	<p>J-Channel <u>TBJC-1-XXX</u> 10' 6"</p>	
	<p>Ridge Cap 1 <u>TBRC-1-XXX</u> 10' 6"</p>	
	<p>Ridge Cap 2 <u>TBRC-2-XXX</u> 10' 6"</p>	



METAL PRODUCTS
(800) 705-4550

PBRECO4
XXX = Color Code (p. 7)

	<p>Sidewall / End wall</p> <p><u>TBSEF-1-XXX</u></p> <p>10' 6"</p>	
	<p>Sidewall</p> <p><u>TBSW-1-XXX</u></p> <p>10' 6"</p>	
	<p>Snow Brake</p> <p><u>TBSB-1-XXX</u></p> <p>10' 6"</p>	
	<p>Soffitt Trim</p> <p><u>TBST-1-XXX</u></p> <p>10' 6"</p>	



METAL PRODUCTS
(800) 705-4550

PBRECO4
XXX = Color Code (p. 7)

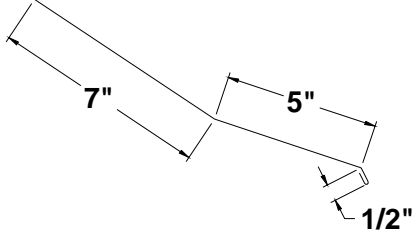
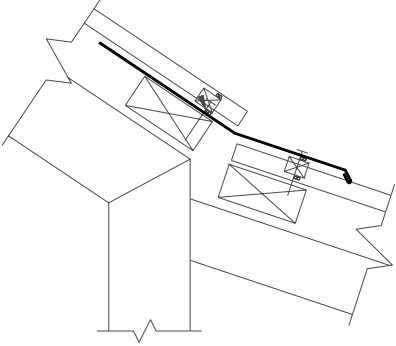
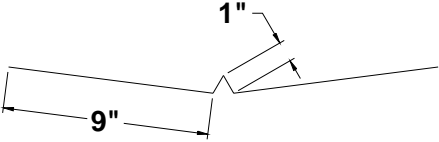
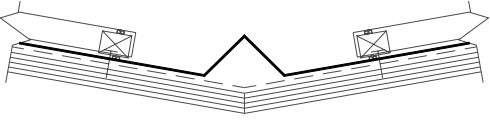
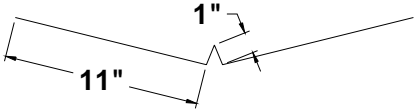
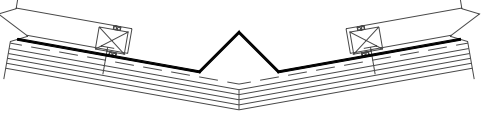
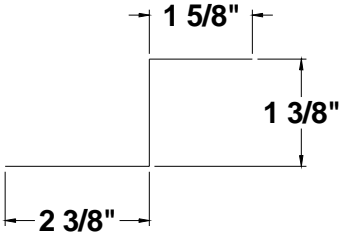
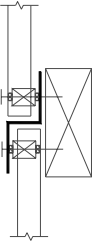
	<p>Transition Flash <u>TBTRF-1-XXX</u> 10' 6"</p>	
	<p>W-Valley <u>TBWV-1-XXX</u> 10' 6"</p>	
	<p>W Valley Flash <u>TBWV-2-XXX</u> 10' 6"</p>	
	<p>Z-Flash <u>TBZF-1-XXX</u> 10' 6"</p>	



METAL PRODUCTS
(800) 705-4550

ECORIB5
Panel

ECORIB5
Panel Profile
Part # PA9-XXX
(XXX = Color Code)

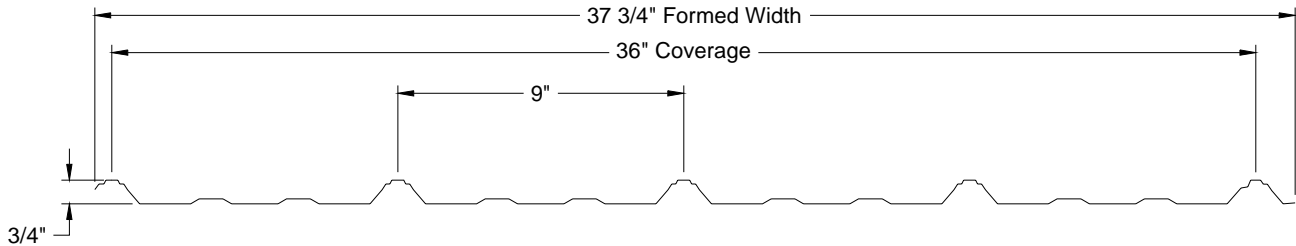

COLOR AVAILABILITY
DURA COAT XT-40S CERANAMEL

<u>COLOR</u>	<u>Code</u>	<u>COLOR</u>	<u>Code</u>	<u>COLOR</u>	<u>Code</u>
China White	217	Terra Cotta	214	Burgundy	272
Bright White	233	Country Red	231	Hawaiian Blue	234
Polar White	221	Cocoa Brown	229	Tahoe Blue	224
Ivory	230	Ash Gray	236	Patina Green	235
Light Stone	220	Old Town Gray	218	Denali Green	225
Sea Wolf	226	Charcoal	227	Emerald Green	232
Sahara Tan	222	Burnished Slate	228	Copper Penny	337
Brownstone	546	Vintage Copper	552	Galvanized (bare)	G
				Galvalume (bare)	Z

NOTES:

- 1.) General Terms and Conditions of Sale will apply to all sales.
- 2.) All formed sheets will be invoiced on a per L/F basis.
- 3.) Maximum standard length per formed sheet is 40'.
 Call for pricing and lead times for lengths over 40'



METAL PRODUCTS
(800) 705-4550

ECORIB5 TRIM
XXX = Color Code (p. 14)

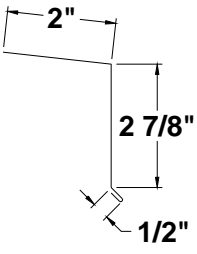
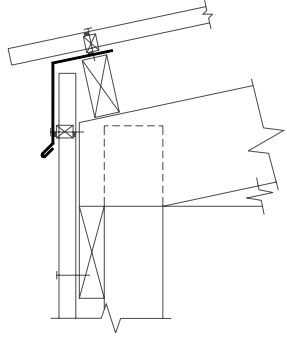
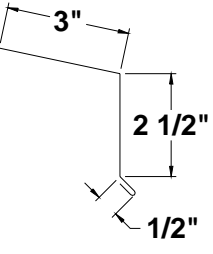
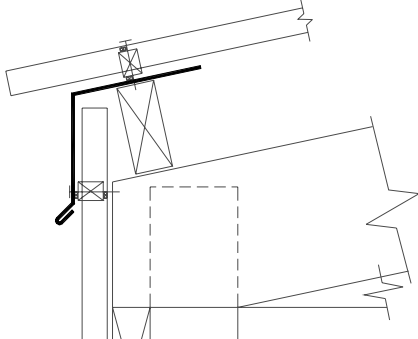
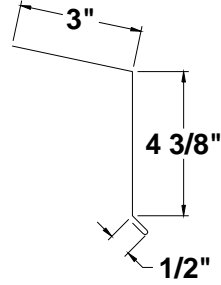
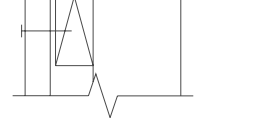
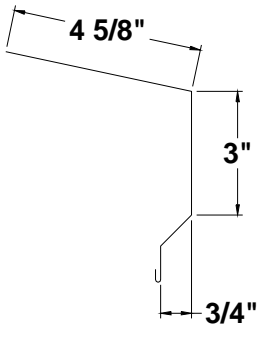
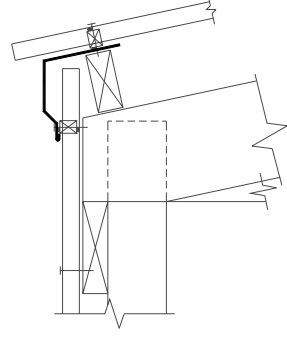
	<p>Eave-Mini <u>TAME-1-XXX</u> 10' 6"</p>	
	<p>Eave 1 <u>TAE-1-XXX</u> 10' 6"</p>	
	<p>Eave 2 <u>TAE-2-XXX</u> 10' 6"</p>	
	<p>Eave 3 <u>TAE-3-XXX</u> 10' 6"</p>	



METAL PRODUCTS
(800) 705-4550

ECORIB5 TRIM
XXX = Color Code (p. 14)

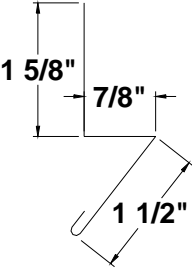
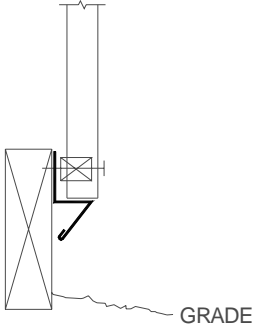
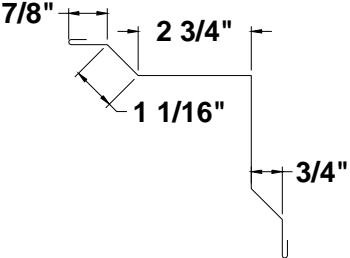
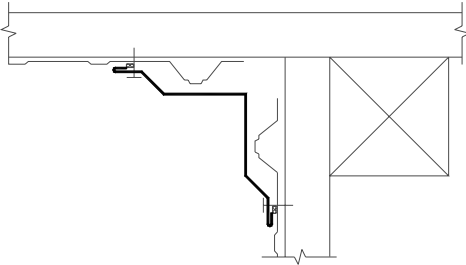
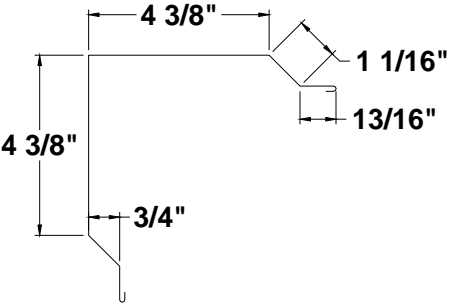
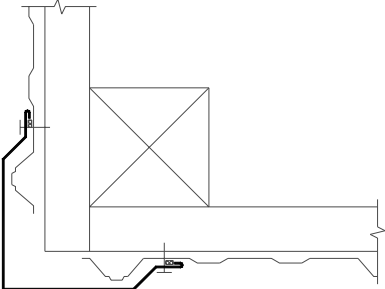
	<p>Base Guard <u>TABG-1-XXX</u> 10' 6"</p>	
	<p>Corner-Inside <u>TAIC-1-XXX</u> 10' 6"</p>	
	<p>Corner-Outside <u>TAOC-1-XXX</u> 10' 6"</p>	



METAL PRODUCTS
(800) 705-4550

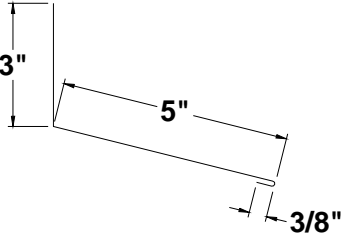
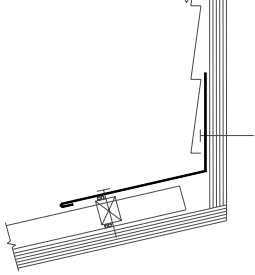
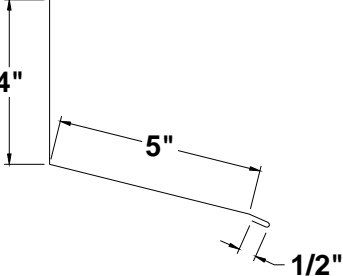
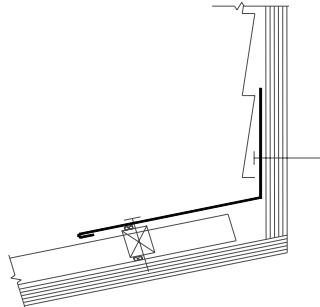
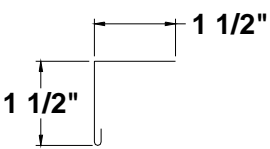
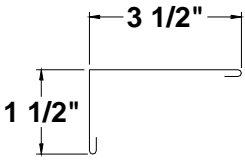
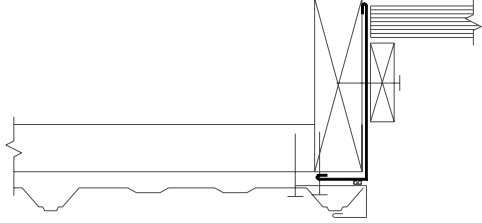
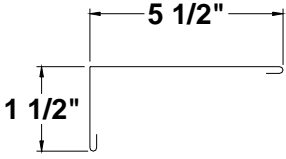

ECORIB5 TRIM
XXX = Color Code (p. 14)

	<p>End wall 1 <u>TAEW-1-XXX</u> 10' 6"</p>	
	<p>End wall 2 <u>TAEW-2-XXX</u> 10' 6"</p>	
	<p>Fascia / Jamb 1.5 <u>TAF-1.5-XXX</u> 10' 6"</p>	
	<p>Fascia / Jamb 3.5 <u>TAF-3.5-XXX</u> 10' 6"</p>	
	<p>Fascia / Jamb 5.5 <u>TAF-5.5-XXX</u> 10' 6"</p>	

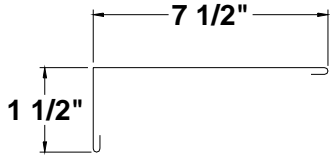
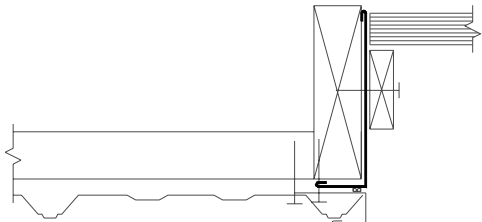
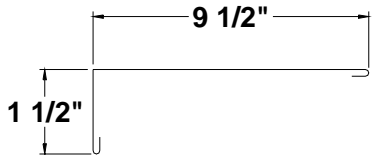

METAL PRODUCTS
(800) 705-4550

ECORIB5 TRIM
XXX = Color Code (p. 14)

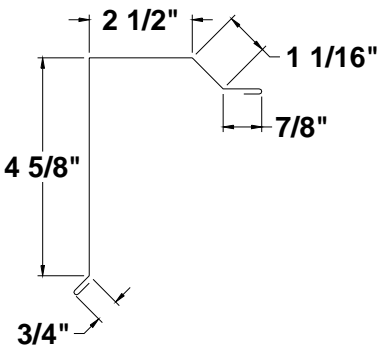
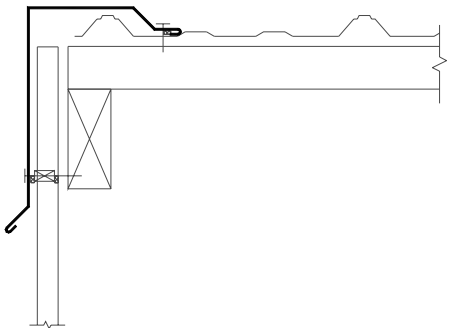
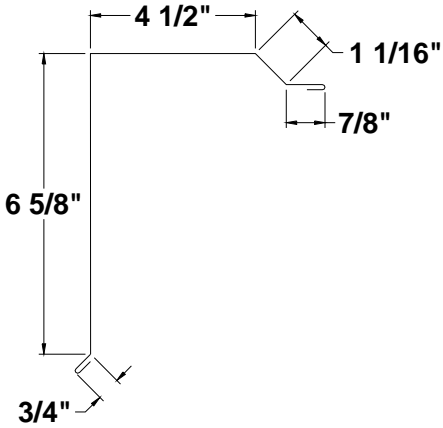
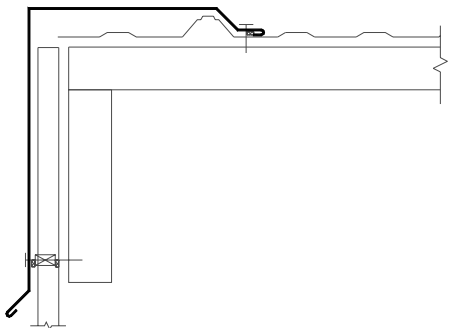
	<p>Fascia / Jamb 7.5 <u>TAF-7.5-XXX</u> 10' 6"</p>	
	<p>Fascia / Jamb 9.5 <u>TAF-9.5-XXX</u> 10' 6"</p>	
	<p>Gable 1 <u>TAG-1-XXX</u> 10' 6"</p>	
	<p>Gable 2 <u>TAG-2-XXX</u> 10' 6"</p>	



METAL PRODUCTS
(800) 705-4550

ECORIB5 TRIM
XXX = Color Code (p. 14)

	<p>Gable-Mini <u>TAMG-1-XXX</u> 10' 6"</p>	
	<p>Gable Trim— Swept Wing <u>TDGSW-1-XXX</u> 10' 6"</p>	
	<p>Gambrel / Slope Transition <u>TAGT-1-XXX</u> 10' 6"</p>	
	<p>Head & Curb Flashing <u>TAHCF-1-XXX</u> 10' 6"</p>	



METAL PRODUCTS
(800) 705-4550

ECORIB5 TRIM
XXX = Color Code (p. 14)

	<p>Header / Drip Cap <u>TADC-1-XXX</u> 10' 6"</p>	
	<p>J- Trim <u>TAJ-1-XXX</u> 10' 6"</p>	
	<p>Jamb Cap-1 <u>TAJC-5-XXX</u> 10' 6"</p>	
	<p>Jamb Cap-2 <u>TAJC-7-XXX</u> 10' 6"</p>	
	<p>Jamb Cap-3 <u>TAJC-9-XXX</u> 10' 6"</p>	



METAL PRODUCTS
(800) 705-4550

ECORIB5 TRIM
XXX = Color Code (p. 14)

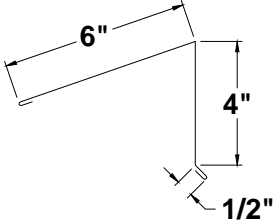
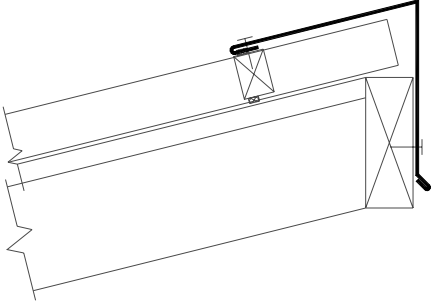
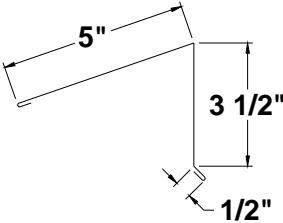
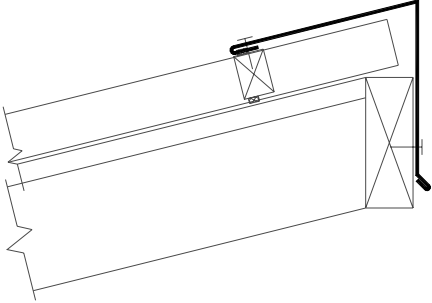
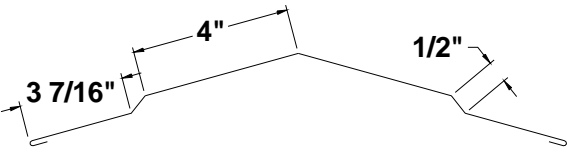
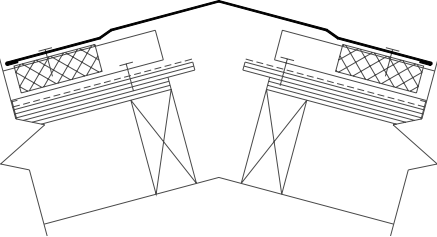
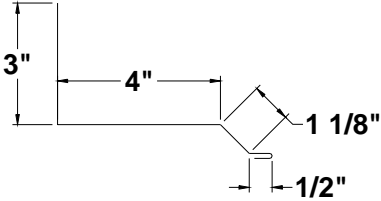
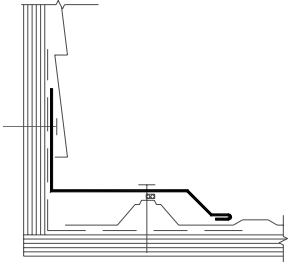
	<p>Peak Cap 1 <u>TAPC-1-XXX</u> 10' 6"</p>	
	<p>Peak Cap 2 <u>TAPC-2-XXX</u> 10' 6"</p>	
	<p>Ridge Cap <u>TARC-1-XXX</u> 10' 6"</p>	
	<p>Sidewall <u>TASW-1-XXX</u> 10' 6"</p>	



METAL PRODUCTS
(800) 705-4550

ECORIB5 TRIM
XXX = Color Code (p. 14)

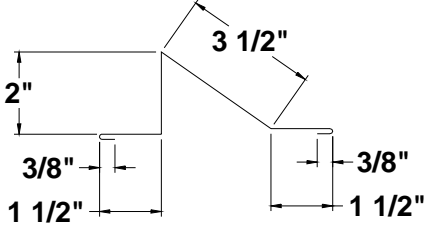
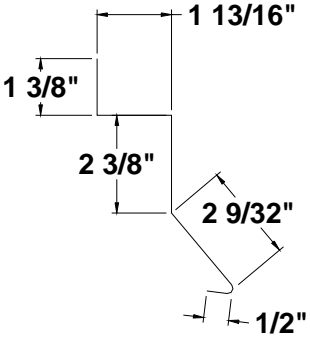
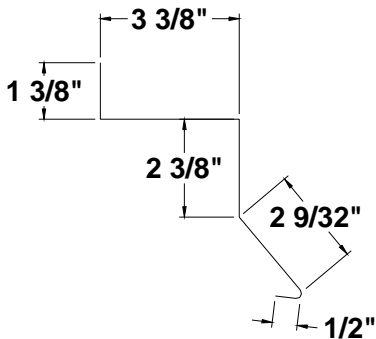
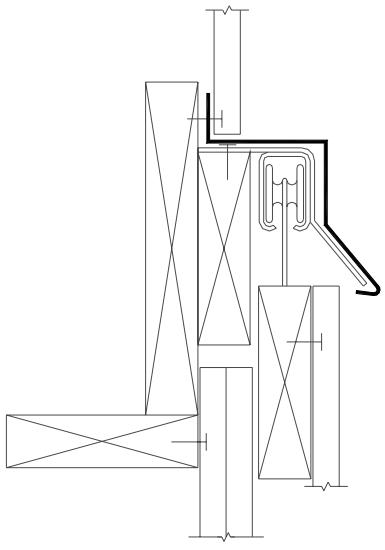
	<p>Snow Brake</p> <p><u>TBSB-1-XXX</u></p> <p>10' 6"</p>	
	<p>Track Cover 2</p> <p><u>TATC-2-XXX</u></p> <p>10' 6"</p> <p>National 5200 Track - 1"</p>	
	<p>Track Cover 3</p> <p><u>TATC-3-XXX</u></p> <p>10' 6"</p> <p>National 5200 Track - 2"</p>	



METAL PRODUCTS
(800) 705-4550

ECORIB5 TRIM
XXX = Color Code (p. 14)

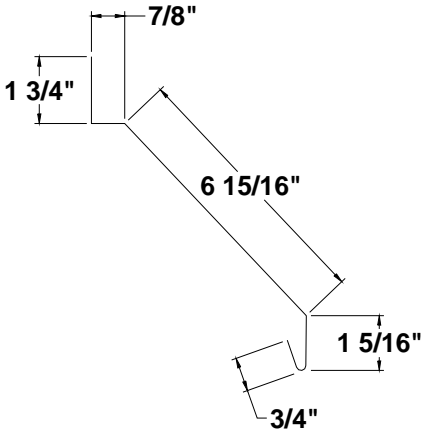
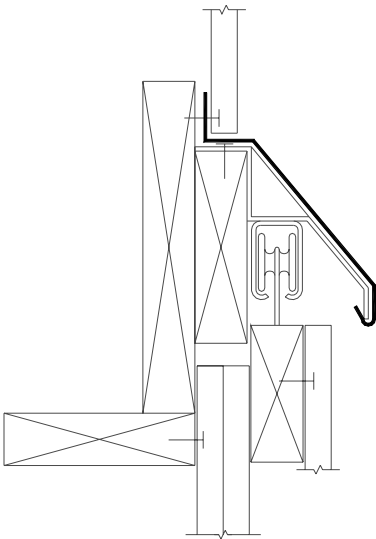
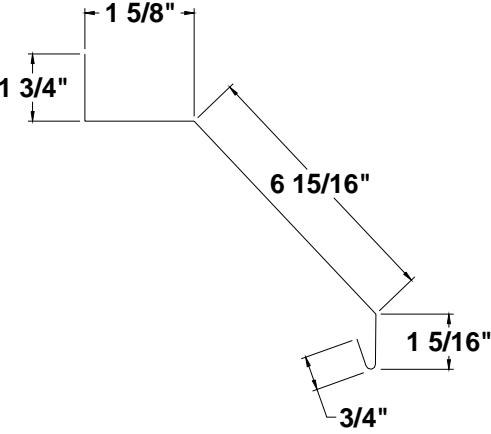
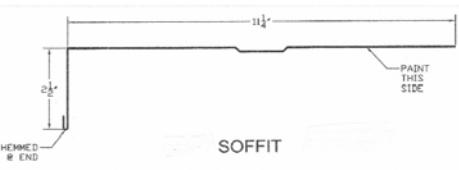
	<p>Track Cover 4 <u>TATC-4-XXX</u> 10' 6" Combo Track</p>	
	<p>Track Cover 5 <u>TATC-5-XXX</u> 10' 6" Combo Track</p>	
	<p>Soffitt <u>TAST-1-XXX</u> 10' 6"</p>	



METAL PRODUCTS
(800) 705-4550

ECORIB5 TRIM
XXX = Color Code (p. 14)

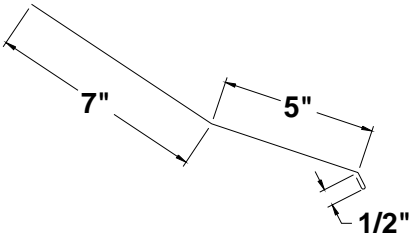
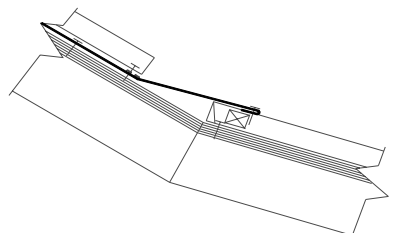
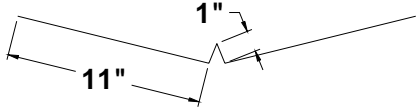
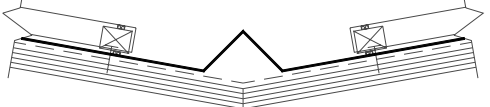
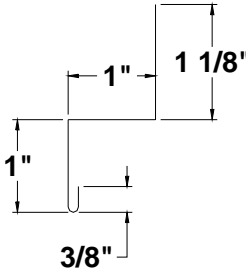
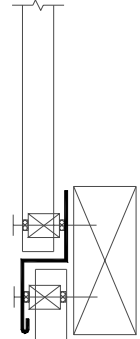
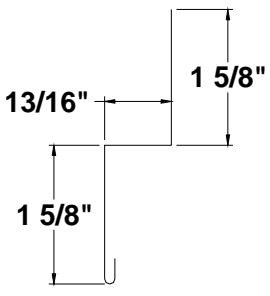
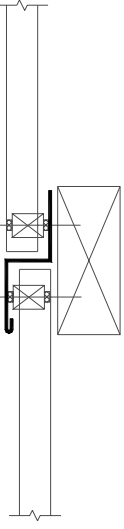
	<p>Transition Flash <u>TATRF-1-XXX</u> 10' 6"</p>	
	<p>W Valley Flash <u>TAWV-1-XXX</u> 10' 6"</p>	
	<p>Wall Light <u>TAWL-1-XXX</u> 10' 6"</p>	
	<p>Zee Trim <u>TAZ-1-XXX</u> 10' 6"</p>	



METAL PRODUCTS
(800) 705-4550

**2-1/2 CORRUGATED
Panel**

**2-1/2 CORRUGATED
Panel Profile
Part # PC9-G**

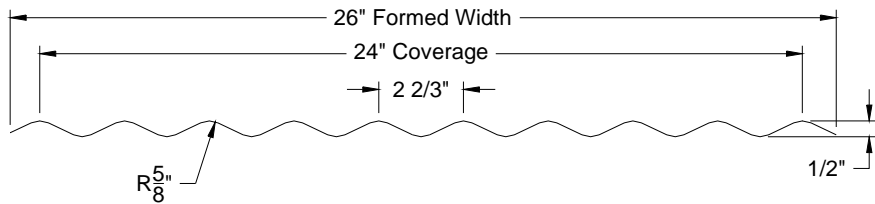

COLOR AVAILABILITY:

Bare only / Clear Coat

8', 10' and 12' STOCK / 50 piece min.

NOTES:

- 1.) General Terms and Conditions of Sale will apply to all sales.
- 2.) All formed sheets will be invoiced on a per L/F basis.
- 3.) **Uses same trim as EcoRib 5 panel**



METAL PRODUCTS
(800) 705-4550

**2-1/2 CORRUGATED
Trim**

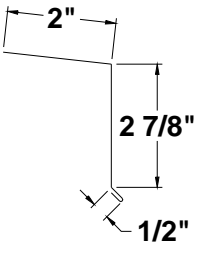
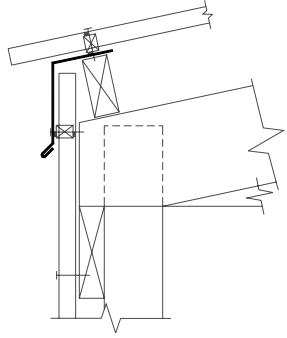
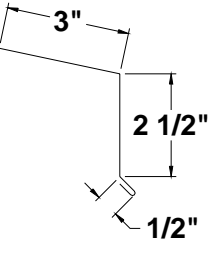
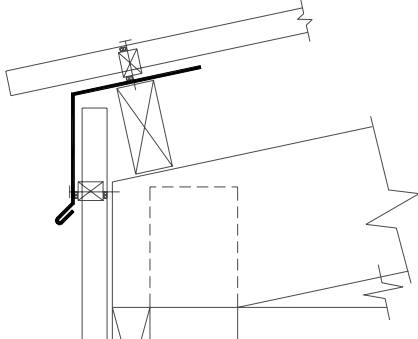
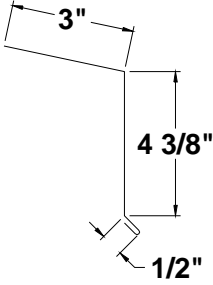
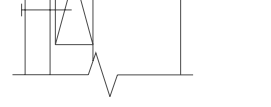
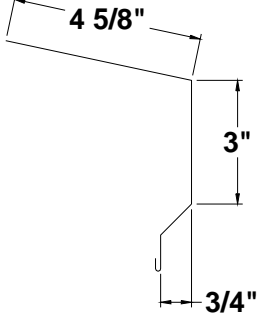
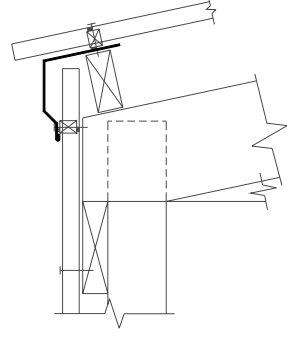
	<p>Eave-Mini <u>TAME-1-G</u> 10' 6"</p>	
	<p>Eave 1 <u>TAE-1-G</u> 10' 6"</p>	
	<p>Eave 2 <u>TAE-2-G</u> 10' 6"</p>	
	<p>Eave 3 <u>TAE-3-G</u> 10' 6"</p>	



METAL PRODUCTS
(800) 705-4550

**2-1/2 CORRUGATED
Trim**

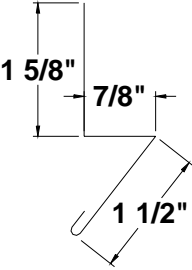
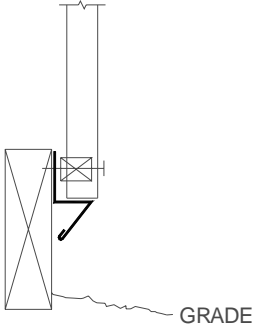
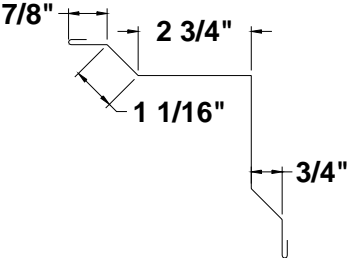
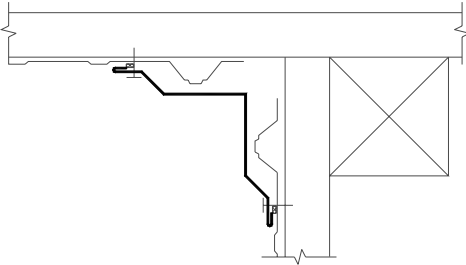
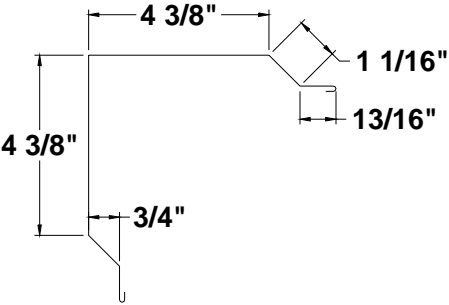
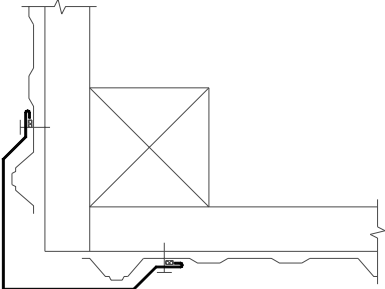
	<p>Base Guard <u>TABG-1-G</u> 10' 6"</p>	
	<p>Corner-Inside <u>TAIC-1-G</u> 10' 6"</p>	
	<p>Corner-Outside <u>TAOC-1-G</u> 10' 6"</p>	



METAL PRODUCTS
(800) 705-4550

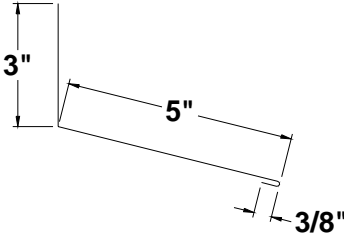
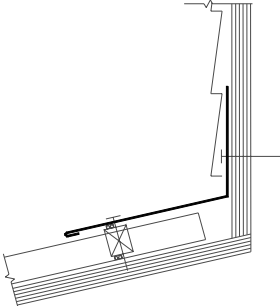
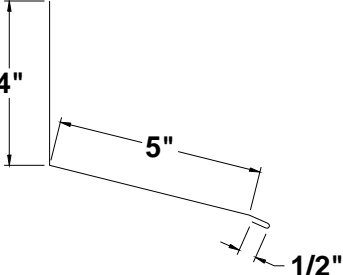
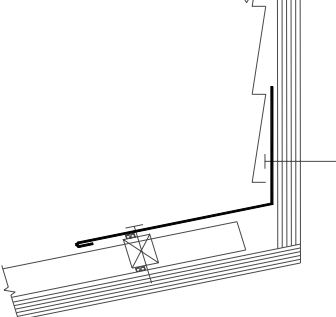
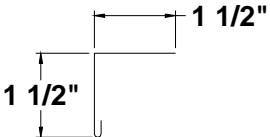
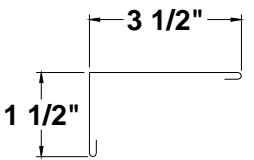
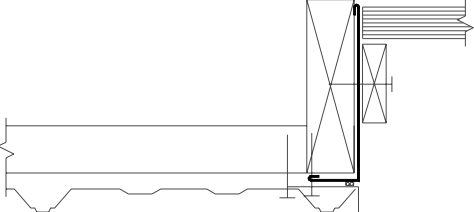
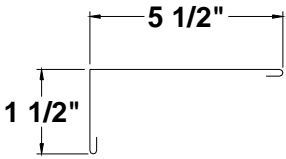

**2-1/2 CORRUGATED
Trim**

	<p>End wall 1 <u>TAEW-1-G</u> 10' 6"</p>	
	<p>End wall 2 <u>TAEW-2-G</u> 10' 6"</p>	
	<p>Fascia / Jamb 1.5 <u>TAF-1.5-G</u> 10' 6"</p>	
	<p>Fascia / Jamb 3.5 <u>TAF-3.5-G</u> 10' 6"</p>	
	<p>Fascia / Jamb 5.5 <u>TAF-5.5-G</u> 10' 6"</p>	

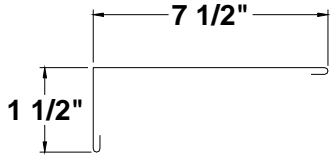
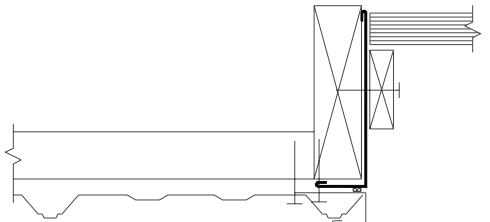
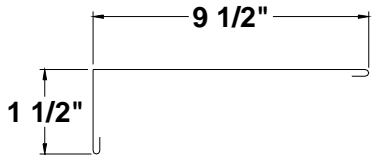

METAL PRODUCTS
(800) 705-4550

**2-1/2 CORRUGATED
Trim**

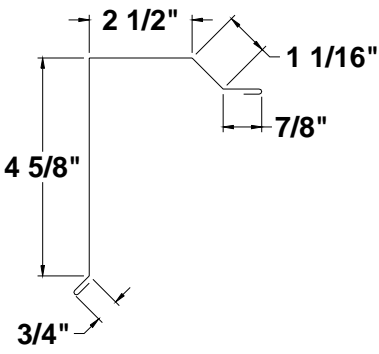
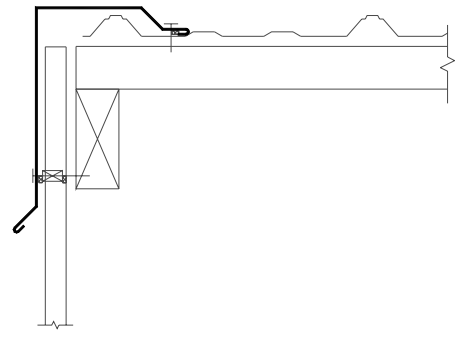
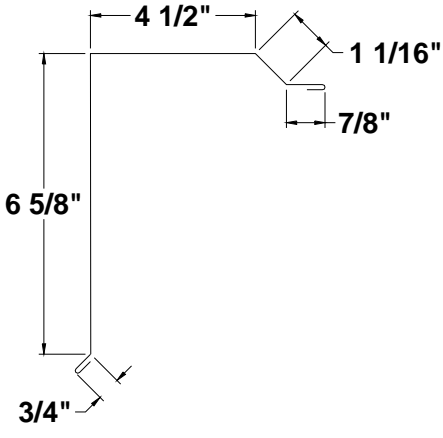
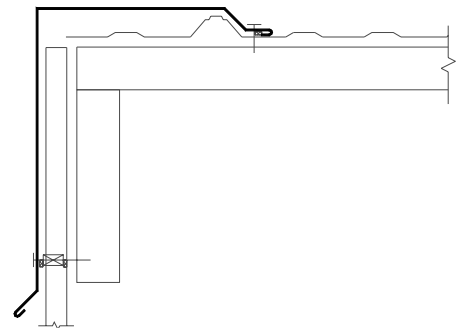
	<p>Fascia / Jamb 7.5 <u>TAF-7.5-G</u> 10' 6"</p>	
	<p>Fascia / Jamb 9.5 <u>TAF-9.5-G</u> 10' 6"</p>	
	<p>Gable 1 <u>TAG-1-G</u> 10' 6"</p>	
	<p>Gable 2 <u>TAG-2-G</u> 10' 6"</p>	



METAL PRODUCTS
(800) 705-4550

**2-1/2 CORRUGATED
Trim**

	<p>Gable-Mini <u>TAMG-1-G</u> 10' 6"</p>	
	<p>Gable Trim— Swept Wing <u>TDGSW-1-G</u> 10' 6"</p>	
	<p>Gambrel / Slope Transition <u>TAGT-1-G</u> 10' 6"</p>	
	<p>Head & Curb Flashing <u>TAHCF-1-G</u> 10' 6"</p>	



METAL PRODUCTS
(800) 705-4550

**2-1/2 CORRUGATED
 Trim**

	<p>Header / Drip Cap <u>TADC-1-G</u> 10' 6"</p>	
	<p>J- Trim <u>TAJ-1-G</u> 10' 6"</p>	
	<p>Jamb Cap-1 <u>TAJC-5-G</u> 10' 6"</p>	
	<p>Jamb Cap-2 <u>TAJC-7-G</u> 10' 6"</p>	
	<p>Jamb Cap-3 <u>TAJC-9-G</u> 10' 6"</p>	



METAL PRODUCTS
(800) 705-4550

**2-1/2 CORRUGATED
Trim**

	<p>Peak Cap 1 <u>TAPC-1-G</u> 10' 6"</p>	
	<p>Peak Cap 2 <u>TAPC-2-G</u> 10' 6"</p>	
	<p>Ridge Cap <u>TARC-1-G</u> 10' 6"</p>	
	<p>Sidewall <u>TASW-1-G</u> 10' 6"</p>	



METAL PRODUCTS
(800) 705-4550

**2-1/2 CORRUGATED
Trim**

	<p>Snow Brake <u>TBSB-1-G</u> 10' 6"</p>	
	<p>Track Cover 2 <u>TATC-2-G</u> 10' 6" National 5200 Track - 1"</p>	
	<p>Track Cover 3 <u>TATC-3-G</u> 10' 6" National 5200 Track - 2"</p>	



METAL PRODUCTS
(800) 705-4550

**2-1/2 CORRUGATED
Trim**

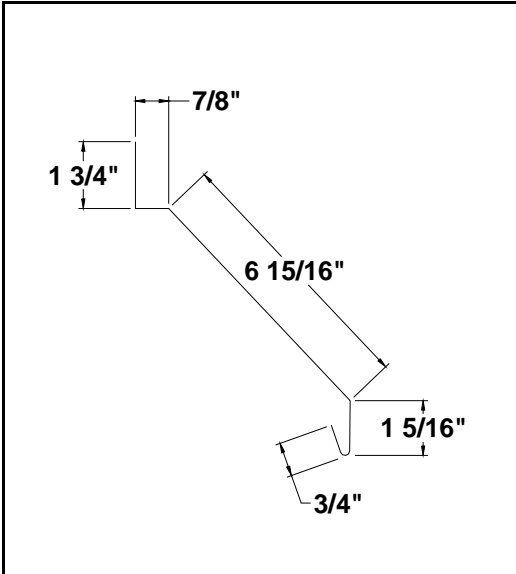

Track Cover 4
TATC-4-G
10' 6"
Combo Track

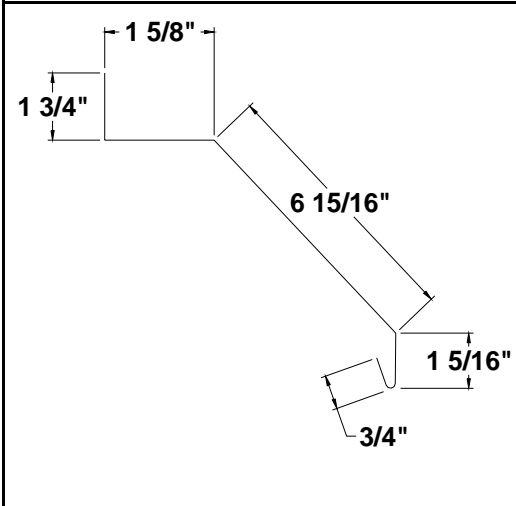

Track Cover 5
TATC-5-G
10' 6"
Combo Track

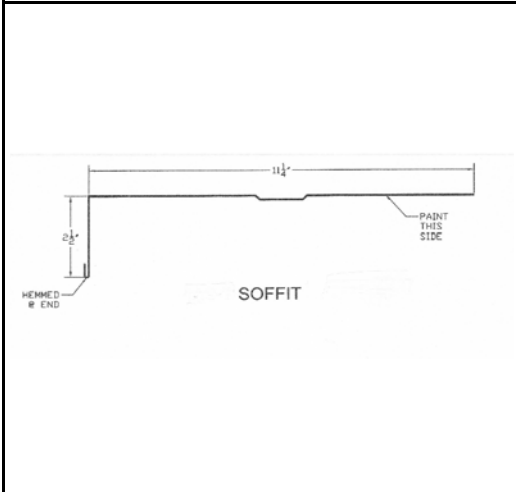
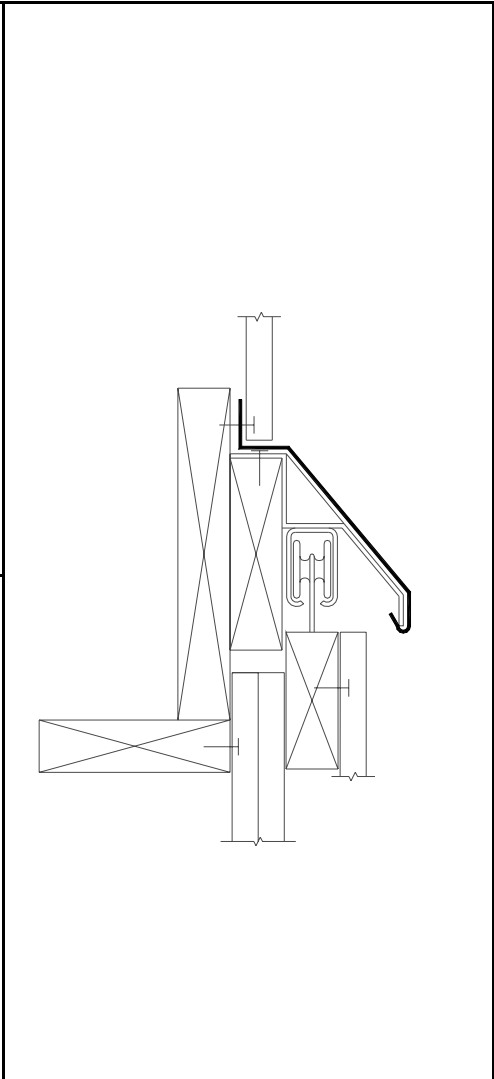

Soffitt
TAST-1-G
10' 6"



METAL PRODUCTS
(800) 705-4550

**2-1/2 CORRUGATED
Trim**

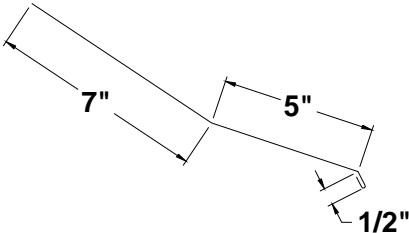
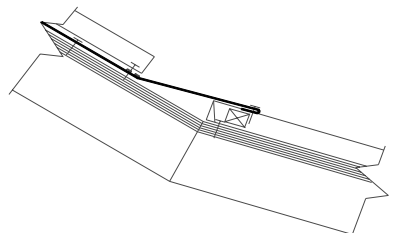
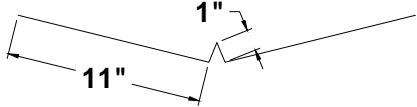
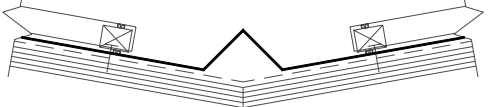
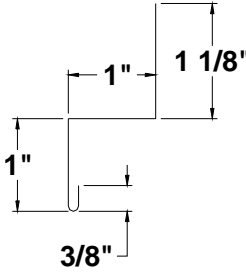
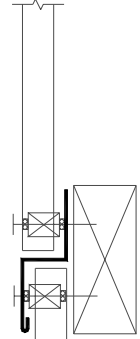
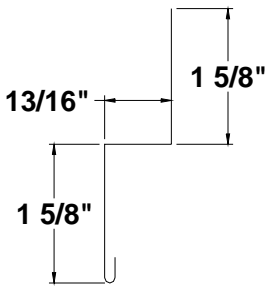
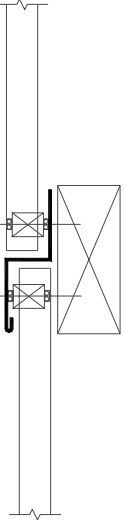
	<p>Transition Flash <u>TATRF-1-G</u> 10' 6"</p>	
	<p>W Valley Flash <u>TAWV-1-G</u> 10' 6"</p>	
	<p>Wall Light <u>TAWL-1-G</u> 10' 6"</p>	
	<p>Zee Trim <u>TAZ-1-G</u> 10' 6"</p>	



METAL PRODUCTS
(800) 705-4550

**ECOLOCK
Panel**

ECOLOCK Panel Profile

Part Numbers: (XXX=color)

- 16" coverage 1" standing seam: PDS6-16/1-XXX**
- 16" coverage 1½" standing seam: PDS6-16/1.5-XXX**
- 12" coverage 1" standing seam: PDS6-12/1-XXX**
- 12" coverage 1½" standing seam: PDS6-12/1.5-XXX**

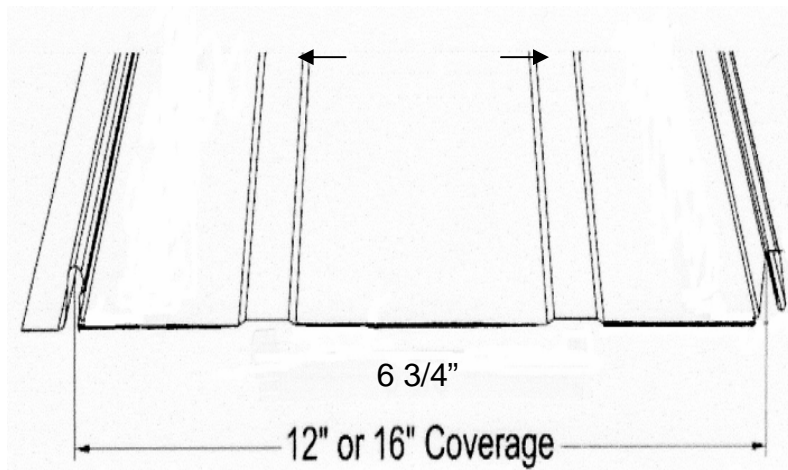

**COLOR AVAILABILITY
DURA COAT XT-40S CERANAMEL**

<u>COLOR</u>	<u>Code</u>	<u>COLOR</u>	<u>Code</u>	<u>COLOR</u>	<u>Code</u>
China White	217	Terra Cotta	214	Burgundy	272
Bright White	233	Country Red	231	Hawaiian Blue	234
Polar White	221	Cocoa Brown	229	Tahoe Blue	224
Ivory	230	Ash Gray	236	Patina Green	235
Light Stone	220	Old Town Gray	218	Denali Green	225
Sea Wolf	226	Charcoal	227	Emerald Green	232
Sahara Tan	222	Burnished Slate	228	Copper Penny	337
Brownstone	546	Vintage Copper	552	Galvanized (bare)	G
				Galvalume (bare)	Z

NOTES:

- 1.) General Terms and Conditions of Sale will apply to all sales.
- 2.) All formed sheets will be invoiced on a per L/F basis.
- 3.) Minimum standard length per formed sheet is 2'.
- 4.) Panels **do not end lap**.
- 5.) Crating charges will apply.



METAL PRODUCTS
(800) 705-4550

ECOLOCK TRIM
XXX = Color Code (P. 36)

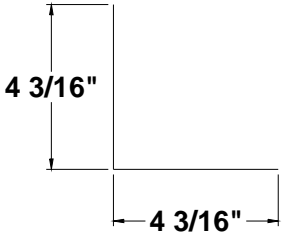
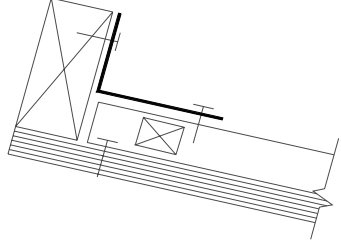
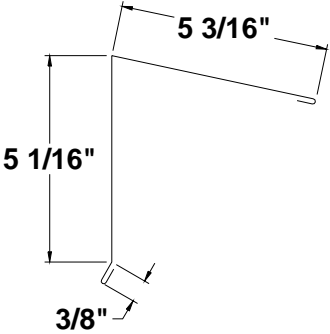
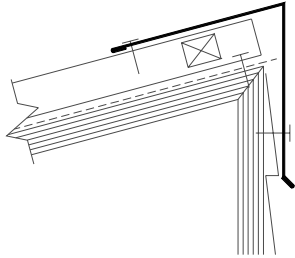
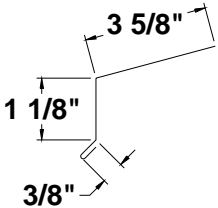
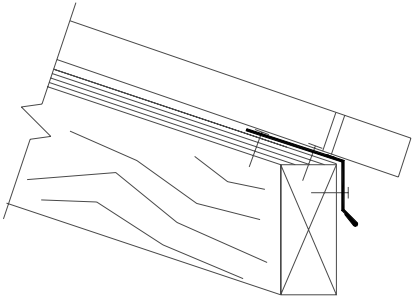
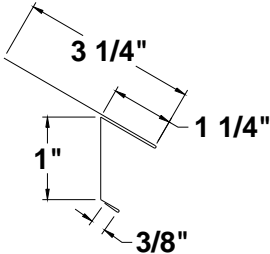
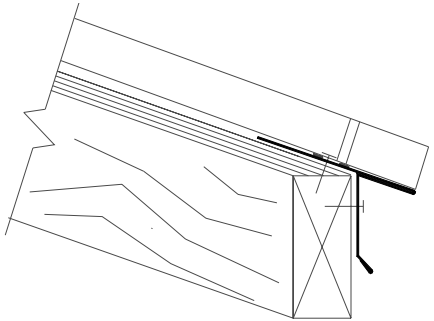
	<p>Bottom Flash TDBF-1-XXX 10' 6"</p>	
	<p>Clear Story TDCS-XXX 10' 6"</p>	
	<p>Eave 1 TDE-1-XXX 10' 6"</p>	
	<p>Eave 2 TDE-2-XXX 10' 6"</p>	



METAL PRODUCTS
(800) 705-4550

ECOLock TRIM
XXX = Color Code (P. 36)

	<p>End wall 1</p> <p><u>TDEW-1-XXX</u></p> <p>10' 6"</p>	
	<p>End wall 2</p> <p><u>TDEW-2-XXX</u></p> <p>10' 6"</p>	
	<p>Gable Trim 1</p> <p><u>TDG-1-XXX</u></p> <p>10' 6"</p>	
	<p>Gable Trim 2</p> <p><u>TDG-2-XXX</u></p> <p>10' 6"</p>	



METAL PRODUCTS
(800) 705-4550

ECOLock TRIM
XXX = Color Code (P. 36)

	<p>Gable Trim— Swept Wing</p> <p><u>TDGSW-1-XXX</u></p> <p>10' 6"</p>	
	<p>Gambrel / Slope Transition</p> <p><u>TDGT-1-XXX</u></p> <p>10' 6"</p>	
	<p>Hip Cap</p> <p><u>TDHC-1-XXX</u></p> <p>10' 6"</p>	
	<p>Ridge / Hip J Flash</p> <p><u>TDRH-1-XXX</u></p> <p>10' 6"</p>	



METAL PRODUCTS
(800) 705-4550



ECOLock TRIM
XXX = Color Code (P. 36)

	<p>Ridge Cap 1 <u>TDRC-1-XXX</u> 10' 6" "</p>	
	<p>Ridge Cap 2 <u>TDRC-2-XXX</u> 10' 6" "</p>	
	<p>Sidewall 1 <u>TDSW-1-XXX</u> 10' 6" "</p>	
	<p>Sidewall 2 <u>TDSW-2-XXX</u> 10' 6" "</p>	

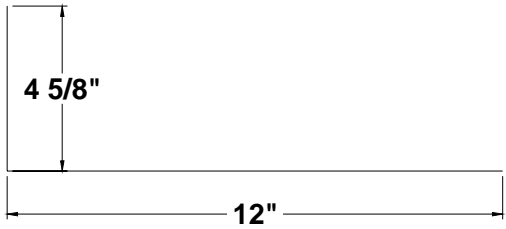
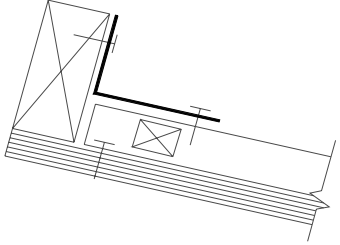
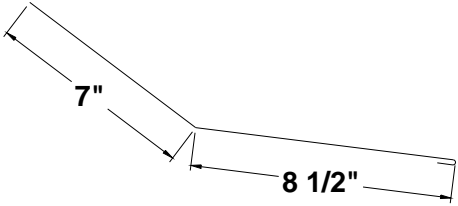
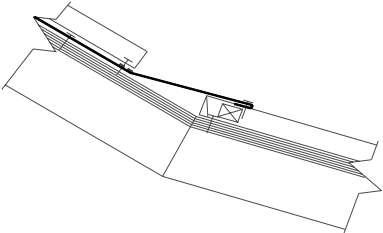
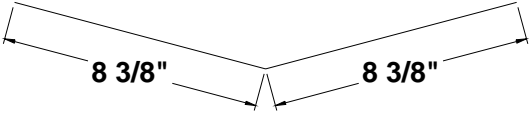
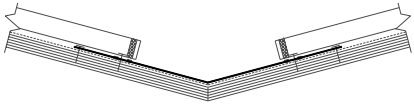

METAL PRODUCTS
(800) 705-4550

ECOLock TRIM
XXX = Color Code (P. 36)

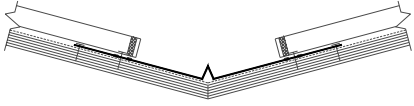
	<p>Top Flash— Skylight / Chimney</p> <p><u>TDTF-1-XXX</u></p> <p>10' 6"</p>	
	<p>Transition</p> <p><u>TDTRF-1-XXX</u></p> <p>10' 6"</p>	
	<p>V-Valley</p> <p><u>TDVV-2-XXX</u></p> <p>10' 6"</p>	
	<p>W Valley</p> <p><u>TDWV-1-XXX</u></p> <p>10' 6"</p>	



METAL PRODUCTS
(800) 705-4550

Standard
EDGE FLASHINGS
xxx = Color Code (p. 6)

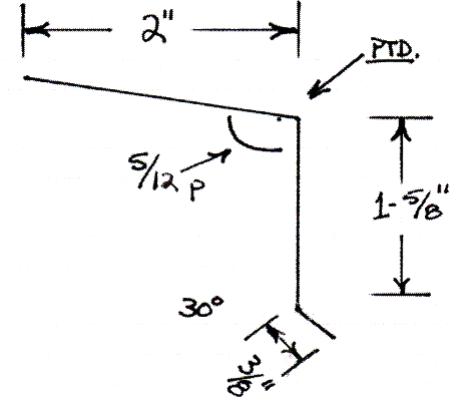
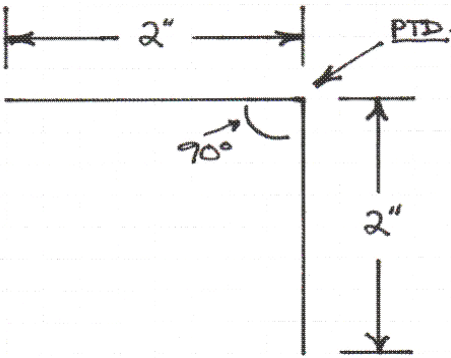
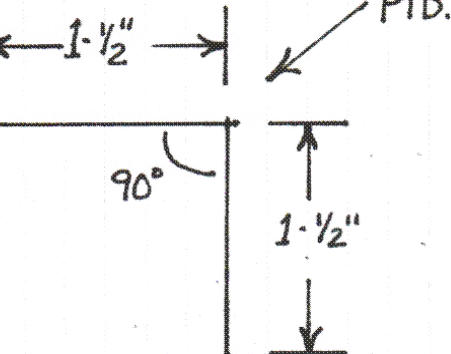
	<p>2" STYLE "G"</p> <p>TFE-1-xxx</p> <p>Length: 10' 6"</p>
	<p>2" x 2" ANGLE</p> <p>TFE-2-XXX</p> <p>Length: 10' 6"</p>
	<p>1-1/2" x 1-1/2" ANGLE</p> <p>TFE-3-XXX</p> <p>Length: 10' 6"</p>



METAL PRODUCTS
(800) 705-4550

**Standard
EDGE FLASHINGS**
xxx = Color Code (p. 6)

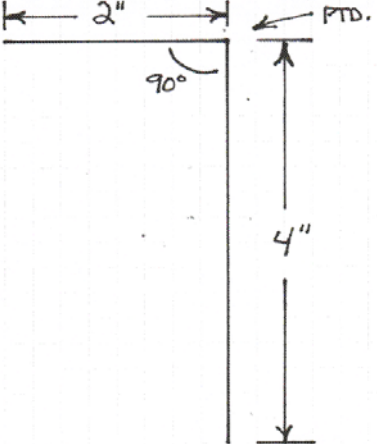
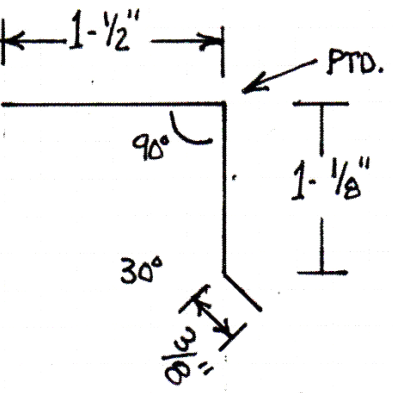
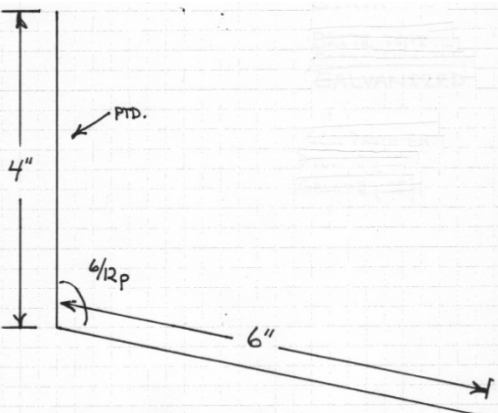
	<p>2" x 4" ANGLE</p> <p>TFE-4-xxx</p> <p>Length: 10' 6"</p>
	<p>1-1/2" STYLE "G"</p> <p>TFE-5-XXX</p> <p>Length: 10' 6"</p>
	<p>ENDWALL</p> <p>TFE-6-XXX</p> <p>Length: 10' 6"</p>



METAL PRODUCTS
(800) 705-4550

Standard
EDGE FLASHINGS
xxx = Color Code (p. 6)

	<p>CAP METAL</p> <p>TFE-7-xxx</p> <p>Length: 10' 6"</p>
	<p>GRAVEL STOP</p> <p>TFE-8-XXX</p> <p>Length: 10' 6"</p>
	<p>STYLE "D"</p> <p>TFE-9-XXX</p> <p>Length: 10' 6"</p>



METAL PRODUCTS
(800) 705-4550

Standard
EDGE FLASHINGS
xxx = Color Code (p. 6)

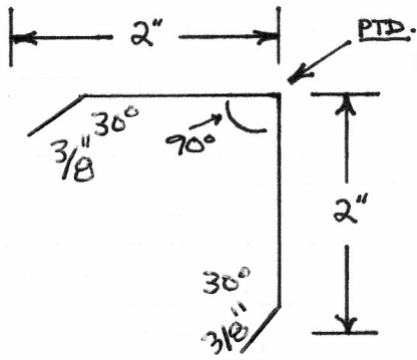
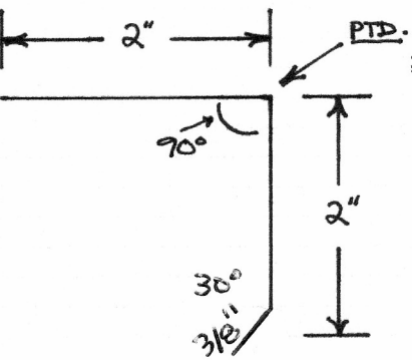
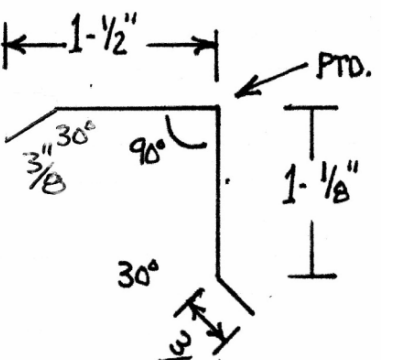
	<p>2" ANGLE DOUBLE GRIPPER</p> <p>TFE-11-xxx</p> <p>Length: 10' 6"</p>
	<p>2" ANGLE SINGLE GRIPPER</p> <p>TFE-12-XXX</p> <p>Length: 10' 6"</p>
	<p>1-1/2" x 1-1/2" "G" WITH GRIPPER</p> <p>TFE-13-XXX</p> <p>Length: 10' 6"</p>



METAL PRODUCTS
(800) 705-4550

Standard
EDGE FLASHINGS
xxx = Color Code (p. 6)

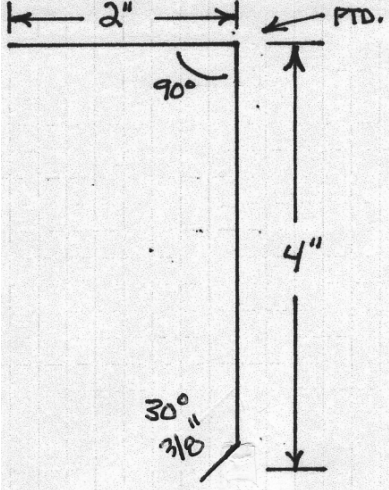
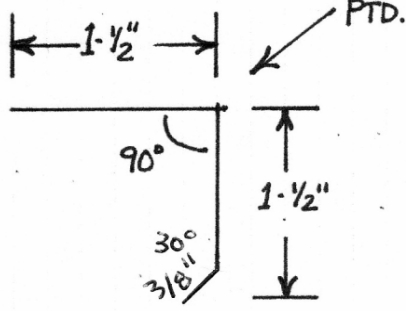
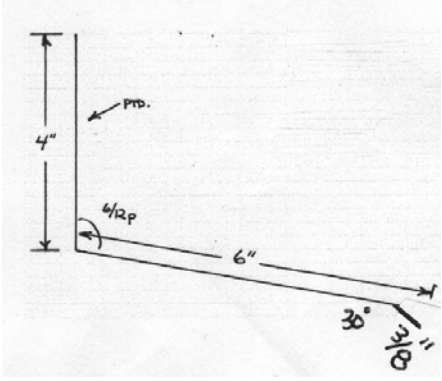
	<p>2" X 4" ANGLE WITH GRIPPER</p> <p>TFE-14-xxx</p> <p>Length: 10' 6"</p>
	<p>1-1/2" ANGLE WITH SINGLE GRIPPER</p> <p>TFE-15-XXX</p> <p>Length: 10' 6"</p>
	<p>ENDWALL WITH GRIPPER</p> <p>TFE-16-XXX</p> <p>Length: 10' 6"</p>



METAL PRODUCTS
(800) 705-4550

Standard
EDGE FLASHINGS
xxx = Color Code (p. 6)

	<p>2" 5/12 ANGLE WITH GRIPPER</p> <p>TFE-17-xxx</p> <p>Length: 10' 6"</p>
	<p>2" "G" WITH SINGLE GRIPPER</p> <p>TFE-18-xxx</p> <p>Length: 10' 6"</p>
	<p>1-1/2" ANGLE WITH DOUBLE GRIPPER</p> <p>TFE-19-xxx</p> <p>Length: 10' 6"</p>



METAL PRODUCTS
(800) 705-4550

Fasteners
Metal to Metal

12-14 Self Driller w/Sealer



Metal panel to metal

Self Drilling fastener

Material thickness:
 .035 - .210

5/16" Hex washer head

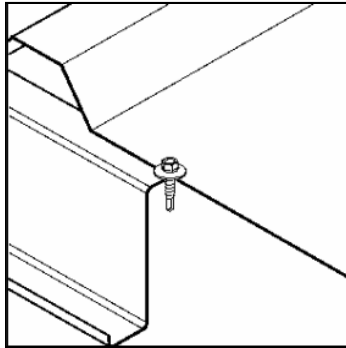

Zinc Plated Steel

Extended corrosion resistance

Cupped HWH head fastener
 with EPDM sealing washer

Unpainted or Painted
 to match panel color

Length
 1"
 1-1/2"

AFP Part Number:
 SP-XXX-12-1
 SP-XXX-12-1.5

12-14 X 3/4 Stitch



Panel to panel side lap,
 trim fastening, and other
 stitch applications

Self drills through
 metal panels

1/4" Hex washer head

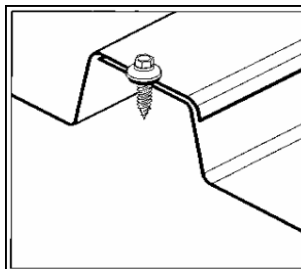

Zinc plated steel

Extended corrosion resistance

Assembled with bond
 sealing washer

Unpainted or Painted
 to match panel color

AFP Part Number: SP-XXX-12-14-.75



METAL PRODUCTS
(800) 705-4550

Fasteners
Metal to Metal

14 X 7/8 Sealer Lap Self Driller



For metal to metal

Panel to panel side lap,
 trim fastening, and other
 stitch applications

5/16" Hex Washer Head

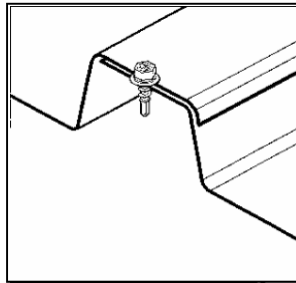

Zinc plated steel

Extended corrosion resistance

Cupped HWH head fastener
 with EPDM seal washer

Unpainted or painted
 to match panel color

AFP Part Number: SP-XXX-1/4-14-.875

Rivet (1/8" diameter X 3/16 max grip)

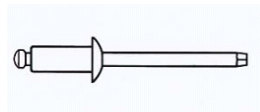

Metal to metal trim and
 gutter fastening

Grip Range .126 - .187

1/8" Diameter

3/16 Max Grip

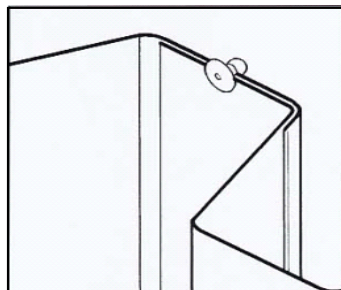

Blind Rivet - Install with
 blind rivet tool

Stainless Steel Body

Stainless Steel Mandrel

Unpainted or painted
 to match panel color

AFP Part Number: SP-XXX-43



METAL PRODUCTS
(800) 705-4550

Fasteners
Metal to Wood

#9 Metal to Wood Sealers



Self drills through metal panel and taps into wood

1/4" Hex Washer Head

Conical shaped bonded sealing washer

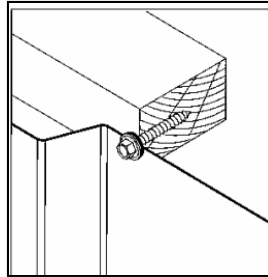

Zinc plated steel

Extended corrosion resistance

Unpainted or painted to match panel color

<u>Length</u>	<u>Part Number</u>
1"	SW-xxx-1
1-1/2"	SW-xxx-1.5
2"	SW-xxx-2

Modified Truss Head	Part #	
	#8 x 1"	SW-G-8-18-1
	#8 x 1 5/8"	SW-G-8-18-1.625

FOR USE WITH CONCEALED FASTENER PANELS



METAL PRODUCTS
(800) 705-4550

Polycarbonate Panels

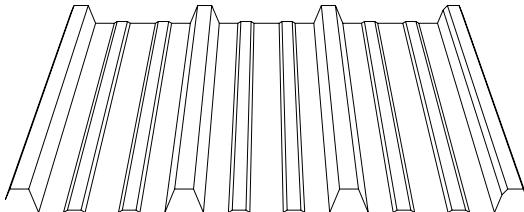
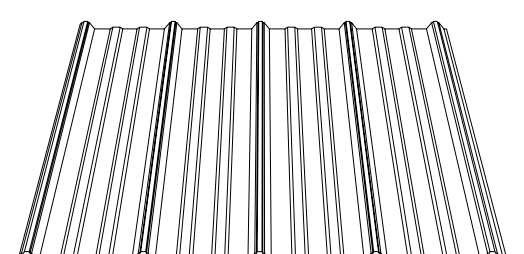
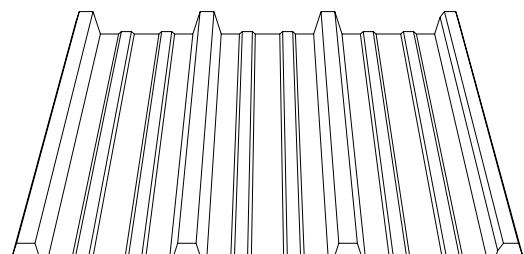
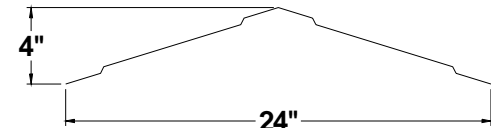
		Part #
	<p>Fiberglass Panels PBR ECO-4 White - 8 oz</p> <p style="text-align: center;">39" x 12'</p>	PB-FIBER-12W
	<p>Sunsky Polycarbonate Panels - Eco-Rib 5 Panel Clear or Soft White</p> <p style="text-align: center;">38" x 8' 38" x 10' 38" x 12'</p>	<p style="text-align: center;">C = Clear W = White</p> <p style="text-align: center;">PA-POLY-8C or 8W PA-POLY-10C or 10W PA-POLY-12C or 12W</p>
	<p>Sunsky Polycarbonate Panels - PBR ECO-4 Soft White</p> <p style="text-align: center;">39" x 12'</p>	PB-POLY-12W
	<p>Sunsky Polycarbonate Ridge Cap</p> <p style="text-align: center;">24" x 10' 6"</p>	PA-POLY-RCW



METAL PRODUCTS
(800) 705-4550

Roll-up Doors

Roll-up Doors
 Three grades of wind-load rated roll-up doors are available:
Mini-door (hand-operated, push-up)
Light commercial (chain driven)
Standard commercial (chain driven)
 (motorized upgrade available on commercial doors)
 (7 days standard lead time for white doors;
 extended lead time for doors other than white)

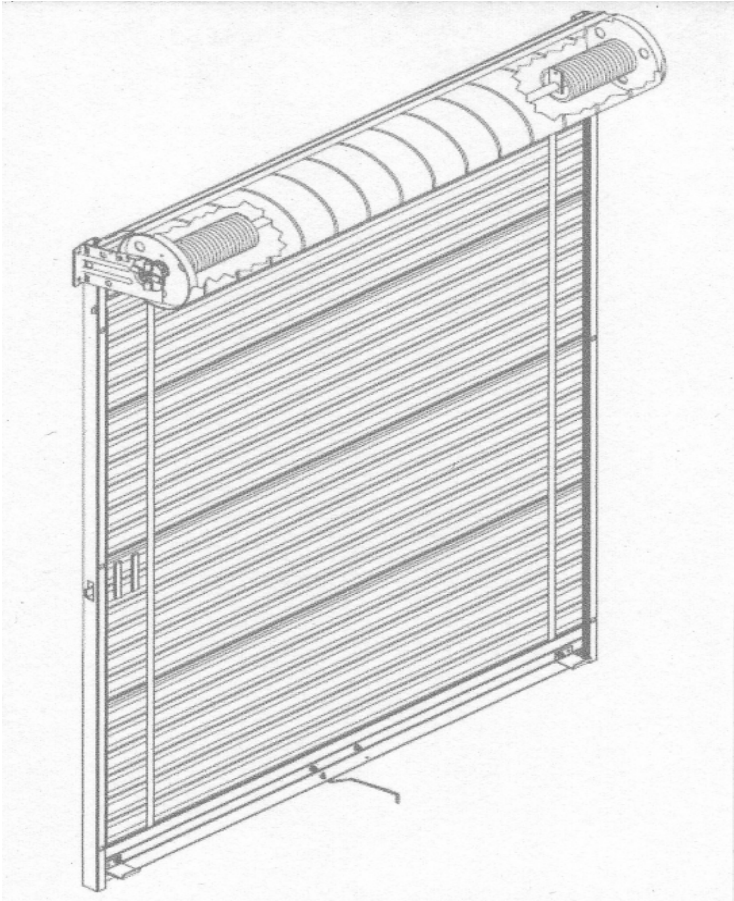

<u>Color #</u>	<u>Color</u>
221	White
234	Polar Blue
224	Royal Blue
232	Forest Green
251	Evergreen
252	Fern Green
253	Dark Teal
254	Teal
255	Marine Green
217	Glossy White
218	Silhouette Gray
220	Buckskin
222	Desert Tan
229	Continental Brown
228	Bronze
256	Cedar Red
257	Valentine Red
258	Tangerine
259	Sunset Orange



Available sizes in the *mini roll-up doors (push-up)*

<u>W x H</u>	<u>Part # (w/3 digit color # for white)</u>	<u>W x H</u>	<u>Part # (w/3 digit color # for white)</u>
3' x 6'8"	PDRR-A-SP-3x6.67-221	6' x 7'	PDRR-A-SP-6x7-221
3' x 7'	PDRR-A-SP-3x7-221	6' x 7'4"	PDRR-A-SP-6x7.34-221
3' x 7'4"	PDRR-A-SP-3x7.34-221	6' x 8'	PDRR-A-SP-6x8-221
3' x 8'	PDRR-A-SP-3x8-221	7' x 6'6"	PDRR-A-SP-7x6.67-221
3'4" x 6'8"	PDRR-A-SP-3.34x6.67-221	7' x 7'	PDRR-A-SP-7x7-221
3'4" x 7'	PDRR-A-SP-3.34x7-221	7' x 7'4"	PDRR-A-SP-7x7.34-221
3'4" x 7'4"	PDRR-A-SP-3.34x7.34-221	7' x 8'	PDRR-A-SP-7x8-221
3'4" x 8'	PDRR-A-SP-3.34x8-221	8' x 6'8"	PDRR-A-SP-8x6.67-221
3'6" x 6'8"	PDRR-A-SP-3.5x6.67-221	8' x 7'	PDRR-A-SP-8x7-221
3'6" x 7'	PDRR-A-SP-3.5x7-221	8' x 7'4"	PDRR-A-SP-8x7.34-221
3'6" x 7'4"	PDRR-A-SP-3.5x7.34-221	8' x 8'	PDRR-A-SP-8x8-221
3'6" x 8'	PDRR-A-SP-3.5x8-221	8' x 9'	PDRR-A-SP-8x9-221
3'8" x 6'8"	PDRR-A-SP-3.67x6.67-221	8'8" x 6'8"	PDRR-A-SP-8.67x6.67-221
3'8" x 7'	PDRR-A-SP-3.67x7-221	8'8" x 7'	PDRR-A-SP-8.67x7-221
3'8" x 7'4"	PDRR-A-SP-3.67x7.34-221	8'8" x 7'4"	PDRR-A-SP-8.67x7.34-221
3'8" x 8'	PDRR-A-SP-3.67x8-221	8'8" x 8'	PDRR-A-SP-8.67x8-221
4' x 6'8"	PDRR-A-SP-4x6.67-221	8'8" x 9'	PDRR-A-SP-8.67x9-221
4' x 7'	PDRR-A-SP-4x7-221	9' x 6'8"	PDRR-A-SP-9x6.67-221
4' x 7'4"	PDRR-A-SP-4x7.34-221	9' x 7'	PDRR-A-SP-9x7-221
4' x 8'	PDRR-A-SP-4x8-221	9' x 7'4"	PDRR-A-SP-9x7.34-221
5' x 6'8"	PDRR-A-SP-5x6.67-221	9' x 8'	PDRR-A-SP-9x8-221
5' x 7'	PDRR-A-SP-5x7-221	9' x 9'	PDRR-A-SP-9x9-221
5' x 7'4"	PDRR-A-SP-5x7.34-221	9' x 10'	PDRR-A-SP-9x10-221
5' x 8'	PDRR-A-SP-5x8-221	10' x 7'	PDRR-A-SP-10x7-221
5'6" x 6'8"	PDRR-A-SP-5.5x6.67-221	10' x 8'	PDRR-A-SP-10x8-221
5'6" x 7'	PDRR-A-SP-5.5x7-221	10' x 9'	PDRR-A-SP-10x9-221
5'6" x 8'	PDRR-A-SP-5.5x8-221	10' x 10'	PDRR-A-SP-10x10-221
6' x 6'8"	PDRR-A-SP-6x6.67-221		

Wind-load rated doors; Available in 19 colors



METAL PRODUCTS
(800) 705-4550

Roll-up Doors

**Available sizes in the *light*
commercial roll-up doors (chain driven)**

<u>W x H</u>	<u>Part # (w/3 digit color # for white)</u>
8 x 8	PDRR-B-SCR-8x8-221
8 x 9	PDRR-B-SCR-8x9-221
8 x 10	PDRR-B-SCR-8x10-221
8 x 12	PDRR-B-SCR-8x12-221
8 x 14	PDRR-B-SCR-8x14-221
9 x 8	PDRR-B-SCR-9x8-221
9 x 9	PDRR-B-SCR-9x9-221
9 x 10	PDRR-B-SCR-9x10-221
9 x 12	PDRR-B-SCR-9x12-221
9 x 14	PDRR-B-SCR-9x14-221
10 x 8	PDRR-B-SCR-10x8-221
10 x 9	PDRR-B-SCR-10x9-221
10 x 10	PDRR-B-SCR-10x10-221
10 x 12	PDRR-B-SCR-10x12-221
10 x 14	PDRR-B-SCR-10x14-221

Wind-load rated doors; Available in 19 colors



**Available sizes in the *standard*
commercial roll-up doors (chain driven)**

<u>W x H</u>	<u>Part # (w/3 digit color # for white)</u>	<u>W x H</u>	<u>Part # (w/3 digit color # for white)</u>
8 x 8	PDRR-E-SCR-8x8-221	12 x 14	PDRR-E-SCR-12x14-221
8 x 9	PDRR-E-SCR-8x9-221	12 x 16	PDRR-E-SCR-12x16-221
8 x 10	PDRR-E-SCR-8x10-221	12 x 18	PDRR-E-SCR-12x18-221
8 x 12	PDRR-E-SCR-8x12-221	12 x 20	PDRR-E-SCR-12x20-221
8 x 14	PDRR-E-SCR-8x14-221	14 x 8	PDRR-E-SCR-14x8-221
8 x 16	PDRR-E-SCR-8x16-221	14 x 9	PDRR-E-SCR-14x9-221
8 x 18	PDRR-E-SCR-8x18-221	14 x 10	PDRR-E-SCR-14x10-221
8 x 20	PDRR-E-SCR-8x-20-221	14 x 12	PDRR-E-SCR-14x12-221
9 x 8	PDRR-E-SCR-9x8-221	14 x 14	PDRR-E-SCR-14x14-221
9 x 9	PDRR-E-SCR-9x9-221	14 x 16	PDRR-E-SCR-14x16-221
9 x 10	PDRR-E-SCR-9x10-221	14 x 18	PDRR-E-SCR-14x18-221
9 x 12	PDRR-E-SCR-9x12-221	14 x 20	PDRR-E-SCR-14x20-221
9 x 14	PDRR-E-SCR-9x14-221	16 x 8	PDRR-E-SCR-16x8-221
9 x 16	PDRR-E-SCR-9x16-221	16 x 9	PDRR-E-SCR-16x9-221
9 x 18	PDRR-E-SCR-9x18-221	16 x 10	PDRR-E-SCR-16x10-221
9 x 20	PDRR-E-SCR-9x20-221	16 x 12	PDRR-E-SCR-16x12-221
10 x 8	PDRR-E-SCR-10x8-221	16 x 14	PDRR-E-SCR-16x14-221
10 x 9	PDRR-E-SCR-10x9-221	16 x 16	PDRR-E-SCR-16x16-221
10 x 10	PDRR-E-SCR-10x10-221	16 x 18	PDRR-E-SCR-16x18-221
10 x 12	PDRR-E-SCR-10x12-221	16 x 20	PDRR-E-SCR-16x20-221
10 x 14	PDRR-E-SCR-10x14-221	18 x 8	PDRR-E-SCR-18x8-221
10 x 16	PDRR-E-SCR-10x16-221	18 x 9	PDRR-E-SCR-18x9-221
10 x 18	PDRR-E-SCR-10x18-221	18 x 10	PDRR-E-SCR-18x10-221
10 x 20	PDRR-E-SCR-10x20-221	18 x 12	PDRR-E-SCR-18x12-221
12 x 8	PDRR-E-SCR-12x8-221	18 x 14	PDRR-E-SCR-18x14-221
12 x 9	PDRR-E-SCR-12x9-221	18 x 16	PDRR-E-SCR-18x16-221
12 x 10	PDRR-E-SCR-12x10-221	18 x 18	PDRR-E-SCR-18x18-221
12 x 12	PDRR-E-SCR-12x12-221	18 x 20	PDRR-E-SCR-18x20-221

Wind-load rated doors; Available in 19 colors



METAL PRODUCTS
(800) 705-4550

Walk Doors

3'0" X 6'8"
Universal* Man Door
White
PDRMI3068
*swing-in/swing-out
swing-left/swing-right





METAL PRODUCTS
(800) 705-4550

Windows

VINYL FRAME WINDOWS

HORIZONTAL SLIDE STORM WINDOWS

Glass panes with vinyl frames

Two colors available: white (221), brown (229)

Three widths available: 36", 42", 48"

Three heights available: 36", 42", 48"

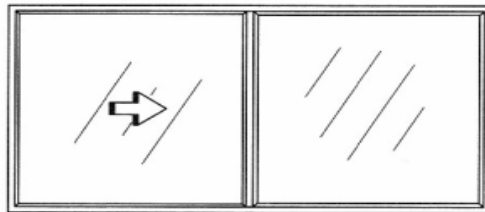

W x H Part # (with 3 digit color # for white)

36" x 36" PWD-VSHN-3636-221
 36" x 42" PWD-VSHN-3642-221
 36" x 48" PWD-VSHN-3648-221

42" x 36" PWD-VSHN-4236-221
 42" x 42" PWD-VSHN-4242-221
 42" x 48" PWD-VSHN-4248-221

48" x 36" PWD-VSHN-4836-221
 48" x 42" PWD-VSHN-4842-221
 48" x 48" PWD-VSHN-4848-221

W x H Part # (with 3 digit color # for brown)

36" x 36" PWD-VSHN-3636-229
 36" x 42" PWD-VSHN-3642-229
 36" x 48" PWD-VSHN-3648-229

42" x 36" PWD-VSHN-4236-229
 42" x 42" PWD-VSHN-4242-229
 42" x 48" PWD-VSHN-4248-229

48" x 36" PWD-VSHN-4836-229
 48" x 42" PWD-VSHN-4842-229
 48" x 48" PWD-VSHN-4848-229



METAL PRODUCTS
(800) 705-4550

Accessories



Accessories Contents

<u>Accessories</u>	<u>Page</u>
Closures	59
Cupolas	60
Flex Seal	60
Insulation	61
Panel Profile Vents	61
Pipe Flashing	62
Roll Valleys	63
Sealants & Tape	63
Touch-up Paint	63
Underlayment	63

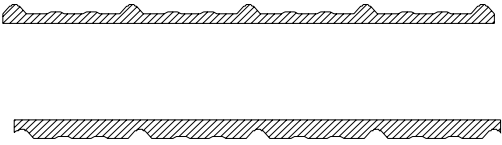
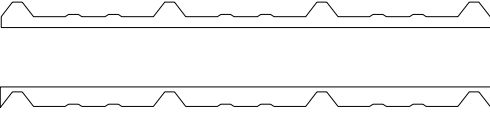

METAL PRODUCTS
(800) 705-4550

Accessories

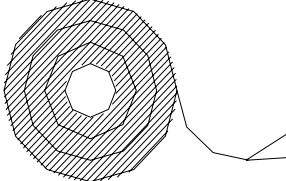

		PART #
	Expanding Foam Closures 1" x 1" x 20' 1" x 1.5" x 15'	PEFC-1X1 PEFC-1x1.5
	Eco-Rib 5 Panel Closures w/Adhesive Inside Outside 36"	PACL-I (inside closure) PACL-O (outside closure)
	PBR ECO-4 Closures w/Adhesive Inside Outside 36"	PBCL-I (inside closure) PBCL-O (outside closure)
	ECO-LOCK Pre-Notched Closure w/Adhesive 16"	PDCL-16
	Universal Memory Foam Closure 1-1/2" x 1-1/2" x 30'	PMCL



METAL PRODUCTS
(800) 705-4550

Accessories

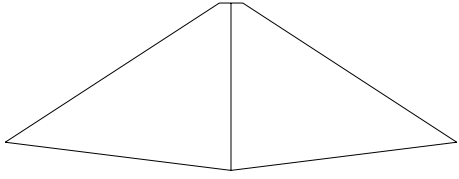
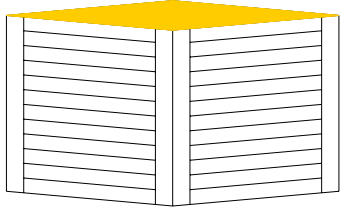
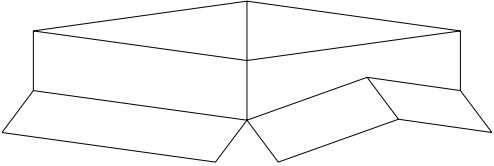
PART #

	<p>Cupola Roof</p> <p>24" x 24" 36" x 36"</p> <p>*Special Order Freight will apply</p>	<p>PCUR-24 PCUR-36</p>
	<p>Cupola Base</p> <p>24" x 24" 36" x 36"</p> <p>*Special Order Freight will apply</p>	<p>PCUB-24 PCUB-36</p>
	<p>Cupola Flashing</p> <p>24" x 24" 36" x 36"</p> <p>*Special Order Freight will apply</p>	<p>PCUF-24 PCUF-36</p>
	<p>Flex-Seal Construction Grade High Performance Roof Sealant</p> <p>10.6 fl. Oz./tube</p>	<p>PC-C</p>



METAL PRODUCTS
(800) 705-4550

Accessories

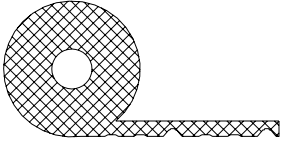
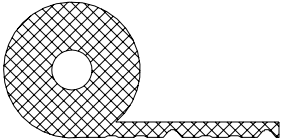
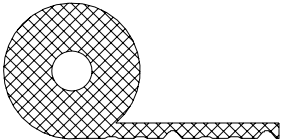
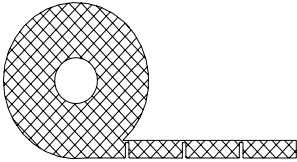
		PART #
	Double Bubble Insulation Reflective, foil/white poly, no tabs 5" x 75" roll (375SF/Roll)	PI2-FWP-5075
	ECO-Rib 5 Panel Profile Vent 1" x 3" x 50' per roll	PAPV
	PBR ECO-4 Profile Vent 1-1/4" X 3" X 25' per roll	PBPV
	ECO-Lock 16" ECO-Lock 12" Profile Vent 1 1/4" x 3" x 50' per roll	PDPV-16 PDPV-12

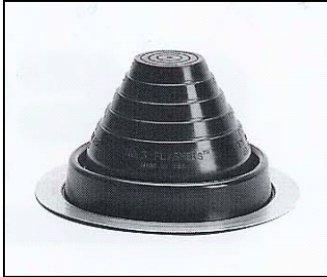
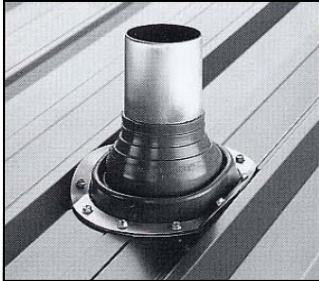

 	<p>Roof Pipe Flashing Round aluminum base Conforms to any panel configuration Gray color EPDM U/M = Each</p>		
	<p><u>Size</u> <u>Description</u></p>	<u>Part #</u>	
	#1	1/4" to 2" pipe gray EPDM	PPFG1
	#2	1-3/4" to 3-1/4" pipe gray EPDM	PPFG2
	#3	1/4" to 5" pipe gray EPDM	PPFG3
	#4	3" to 6-1/4" pipe gray EPDM	PPFG4
	#5	4-1/4" to 7-1/2" pipe gray EPDM	PPFG5
	#6	5" to 9" pipe gray EPDM	PPFG6
	#7	6" to 11" pipe gray EPDM	PPFG7
	#8	7" to 13" pipe gray EPDM	PPFG8
#9	10" to 18" pipe gray EPDM	PPFG9	



METAL PRODUCTS
(800) 705-4550

Accessories

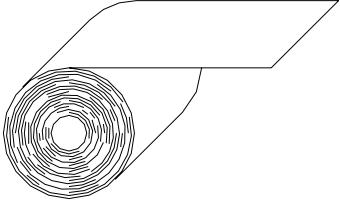
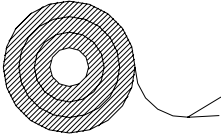
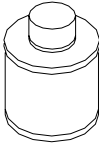
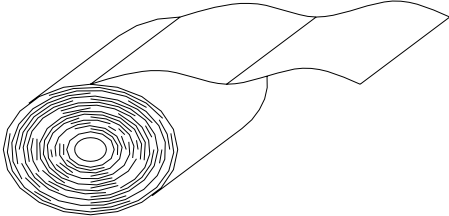
		PART #
	29 ga. Roll Valley 40 7/8" x 25' 0"	2-019-40.875-25-xxx
	40 7/8" x 50' 0"	2-019-40.875-50-xxx
	20 3/8" x 25' 0"	2-019-20.25-25-xxx
	20 3/8" x 50' 0"	2-019-20.25-50-xxx
	Butyl Sealant Tape 3/8" x 3/32" x 45'	BUTYL
	2 oz Bottle w/ brush Touch-up Paint	PTUP-XXX
	Roof Underlayment Vapor barrier 48" x 250' roll	PUL



METAL PRODUCTS
(800) 705-4550

Base Plates & Tube

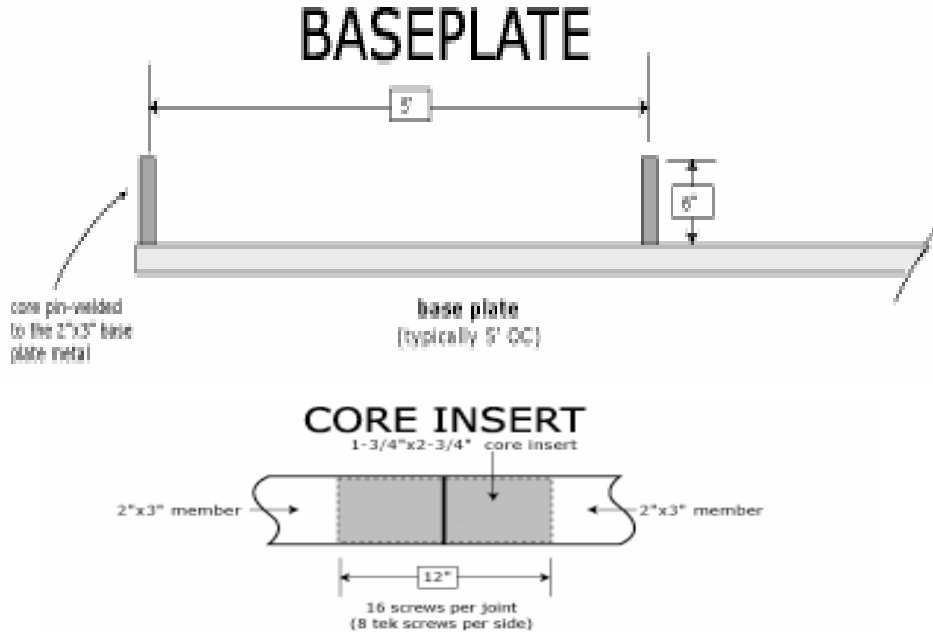

BASEPLATE

<u>Description</u>	<u>U/M</u>	<u>Part #</u>
BASEPLATE (cores 60" oc)	LF	2B-2X3-60
BASEPLATE (cores 54" oc)	LF	2B-2X3-54
BASEPLATE (cores 48" oc)	LF	2B-2X3-48
BASEPLATE (cores 42" oc)	LF	2B-2X3-42
BASEPLATE (cores 36" oc)	LF	2B-2X3-36
BASEPLATE (cores 30" oc)	LF	2B-2X3-30
BASEPLATE (cores custom oc)	LF	2B-2X3-TBD

(Customer specifies exact length and core spacing)

TUBE

<u>Description</u>	<u>U/M</u>	<u>Part #</u>
2" X 3" X 24' 14GA. HDG	LF	2T-F-2X3
2" X 2" X 24' 16GA. HDG	LF	2T-F-2X2
1-3/4" x 2-3/4" x 10' 12GA CRS	EA	1T-12-1.75X2.75X120
1-3/4" x 2-3/4" x 12" 12GA CRS	EA	1T-12-1.75X2.75-12
1-3/4" x 2-3/4" x 6" 12GA CRS	EA	1T-12-1.75X2.75-6



METAL PRODUCTS
(800) 705-4550

Trusses



Description	U/M	Part #
8' TRUSS 3/12	EA	2TO1-8-312
9' TRUSS 3/12	EA	2TO1-9-312
10' TRUSS 3/12	EA	2TO1-10-312
11' TRUSS 3/12	EA	2TO1-11-312
12' TRUSS 3/12	EA	2TO1-12-312
13' TRUSS 3/12	EA	2TO1-13-312
14' TRUSS 3/12	EA	2TO1-14-312
15' TRUSS 3/12	EA	2TO1-15-312
16' TRUSS 3/12	EA	2TO1-16-312
17' TRUSS 3/12	EA	2TO1-17-312
18' TRUSS 3/12	EA	2TO1-18-312
19' TRUSS 3/12	EA	2TO1-19-312
20' TRUSS 3/12	EA	2TO1-20-312
above also available in 2/12 pitch	EA	2TO1-XX-212
above also available in 4/12 pitch	EA	2TO1-XX-412
above also available in 5/12 pitch	EA	2TO1-XX-512
above also available in 6/12 pitch	EA	2TO1-XX-612



Trusses

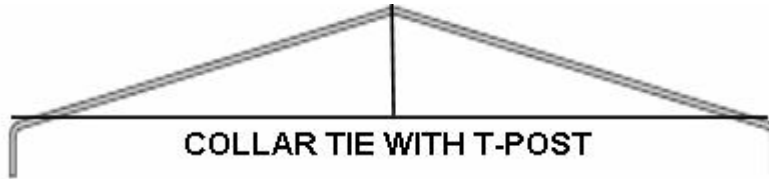

<u>Description</u>	<u>U/M</u>	<u>Assembled Part #</u>	<u>Unassembled* Part #</u>
10' COLLAR-TIE TRUSS 3/12	EA	2TC1-10-312	2TCU-10-312
12' COLLAR-TIE TRUSS 3/12	EA	2TC1-12-312	2TCU-12-312
14' COLLAR-TIE TRUSS 3/12	EA	2TC1-14-312	2TCU-14-312
16' COLLAR-TIE TRUSS 3/12	EA	2TC1-16-312	2TCU-16-312
18' COLLAR-TIE TRUSS 3/12	EA	2TC1-18-312	2TCU-18-312
20' COLLAR-TIE TRUSS 3/12	EA	2TC1-20-312	2TCU-20-312
22' COLLAR-TIE TRUSS 3/12	EA	2TC1-22-312	2TCU-22-312
24' COLLAR-TIE TRUSS 3/12	EA	2TC1-24-312	2TCU-24-312
26' COLLAR-TIE TRUSS 3/12	EA	2TC1-26-312	2TCU-26-312
28' COLLAR-TIE TRUSS 3/12	EA	2TC1-28-312	2TCU-28-312
30' COLLAR-TIE TRUSS 3/12	EA	2TC1-30-312	2TCU-30-312
above also available in 2/12 pitch	EA	2TC1-xx-212	2TCU-xx-212
above also available in 4/12 pitch	EA	2TC1-xx-412	2TCU-xx-412
above also available in 5/12 pitch	EA	2TC1-xx-512	2TCU-xx-512
above also available in 6/12 pitch	EA	2TC1-xx-612	2TCU-xx-612

* Unassembled Trusses 18' and less

- all components included
to be assembled on site
components include
1 open truss
1 collar-tie
1 t-post
5x7 brackets (4 ea)
1-3/4 x 6 brackets (2 ea)
2x2x2 angle bracket (2 ea)
1 bag screws

* Unassembled Trusses 20' and greater

- all components included
to be assembled on site
components include
1 peak bend
2 corner bends
2 rafter tubes cut-to-length
1 collar-tie
1 t-post
5x7x4 truss brackets (4 ea)
1-3/4 x 6 brackets (2 ea)
2x2x2 angle bracket (2 ea)
1 bag screws



METAL PRODUCTS
(800) 705-4550

Trusses

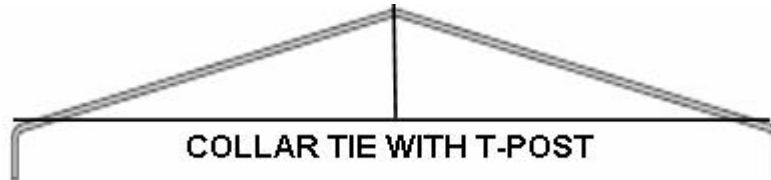

Description

U/M

Part #

COLLAR-TIE TUBE 2" X 2" X 10'	EA	2TC-2X2-10
COLLAR-TIE TUBE 2" X 2" X 12'	EA	2TC-2X2-12
COLLAR-TIE TUBE 2" X 2" X 14'	EA	2TC-2X2-14
COLLAR-TIE TUBE 2" X 2" X 16'	EA	2TC-2X2-16
COLLAR-TIE TUBE 2" X 2" X 18'	EA	2TC-2X2-18
COLLAR-TIE TUBE 2" X 2" X 20'	EA	2TC-2X2-20
COLLAR-TIE TUBE 2" X 2" X 22'	EA	2TC-2X2-22
COLLAR-TIE TUBE 2" X 2" X 24'	EA	2TC-2X2-24
COLLAR-TIE T-POST 2" x 2" x 1'	EA	2T-TP-1
COLLAR-TIE T-POST 2" x 2" x 2'	EA	2T-TP-2
COLLAR-TIE T-POST 2" x 2" x 3'	EA	2T-TP-3
COLLAR-TIE T-POST 2" x 2" x 4'	EA	2T-TP-4
COLLAR-TIE T-POST 2" x 2" x 5'	EA	2T-TP-5
"KICKER" (Support Tube), 2" x 2"	LF	2T-K-2X2
1-3/4" X 6" X 14 ga. Flat Bracket / Pre Drilled	EA	2HB-FB-1.75X6
2" X 2" X 14 ga. Angle Bracket / Pre Drilled	EA	2HB-AB-2X2X2
5-3/4" X 7" X 14 ga. Flat Bracket/ Pre Drilled	EA	2HB-FB-5.75X7x4
FRAMING SCREWS (250/bag)	PKG	SP-G-12-.75 (bag)



Trusses



<u>Description</u>	<u>U/M</u>	<u>Assembled Part #</u>	<u>Unassembled* Part #</u>
21' "W" TRUSS 3/12	EA	2TW1-21-312	2TWU-21-312
22' "W" TRUSS 3/12	EA	2TW1-22-312	2TWU-22-312
23' "W" TRUSS 3/12	EA	2TW1-23-312	2TWU-23-312
24' "W" TRUSS 3/12	EA	2TW1-24-312	2TWU-24-312
25' "W" TRUSS 3/12	EA	2TW1-25-312	2TWU-25-312
26' "W" TRUSS 3/12	EA	2TW1-26-312	2TWU-26-312
27' "W" TRUSS 3/12	EA	2TW1-27-312	2TWU-27-312
28' "W" TRUSS 3/12	EA	2TW1-28-312	2TWU-28-312
29' "W" TRUSS 3/12	EA	2TW1-29-312	2TWU-29-312
30' "W" TRUSS 3/12	EA	2TW1-30-312	2TWU-30-312
31' "W" TRUSS 3/12	EA	2TW1-31-312	2TWU-31-312
32' "W" TRUSS 3/12	EA	2TW1-32-312	2TWU-32-312
33' "W" TRUSS 3/12	EA	2TW1-33-312	2TWU-33-312
34' "W" TRUSS 3/12	EA	2TW1-34-312	2TWU-34-312
35' "W" TRUSS 3/12	EA	2TW1-35-312	2TWU-35-312
36' "W" TRUSS 3/12	EA	2TW1-36-312	2TWU-36-312
37' "W" TRUSS 3/12	EA	2TW1-37-312	2TWU-37-312
38' "W" TRUSS 3/12	EA	2TW1-38-312	2TWU-38-312
39' "W" TRUSS 3/12	EA	2TW1-39-312	2TWU-39-312
40' "W" TRUSS 3/12	EA	2TW1-40-312	2TWU-40-312
above also available in 2/12 pitch	EA	2TW1-xx-212	2TWU-xx-212
above also available in 4/12 pitch	EA	2TW1-xx-412	2TWU-xx-412
above also available in 5/12 pitch	EA	2TW1-xx-512	2TWU-xx-512
above also available in 6/12 pitch	EA	2TW1-xx-612	2TWU-xx-612

* Unassembled = all components included; to be assembled on site;
components include: 1 peak bend 2 corner bends 2 rafter tubes cut-to-length 2x2 collar & "W" web pieces cut-to-length 5x7 brackets (14 ea) 1 bag screws



METAL PRODUCTS
(800) 705-4550

Sub-Components

PEAK BEND



CORNER BEND

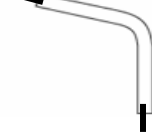

<u>Description</u>	<u>U/M</u>	<u>Part #</u>
PEAK BEND 2/12	EA	2T-PB-212
PEAK BEND 3/12	EA	2T-PB-312
PEAK BEND 4/12	EA	2T-PB-412
PEAK BEND 5/12	EA	2T-PB-512
PEAK BEND 6/12	EA	2T-PB-612
CORNER BEND 2/12	EA	2T-CB-212
CORNER BEND 3/12	EA	2T-CB-312
CORNER BEND 4/12	EA	2T-CB-412
CORNER BEND 5/12	EA	2T-CB-512
CORNER BEND 6/12	EA	2T-CB-612
RAFTER TUBES (for a 10' truss; 3/12)	EA	2RT-10-312
RAFTER TUBES (for a 12' truss; 3/12)	EA	2RT-12-312
RAFTER TUBES (for a 14' truss; 3/12)	EA	2RT-14-312
RAFTER TUBES (for a 16' truss; 3/12)	EA	2RT-16-312
RAFTER TUBES (for a 18' truss; 3/12)	EA	2RT-18-312
RAFTER TUBES (for a 20' truss; 3/12)	EA	2RT-20-312
RAFTER TUBES (for a 22' truss; 3/12)	EA	2RT-22-312
RAFTER TUBES (for a 24' truss; 3/12)	EA	2RT-24-312
RAFTER TUBES (for a 26' truss; 3/12)	EA	2RT-26-312
RAFTER TUBES (for a 28' truss; 3/12)	EA	2RT-28-312
RAFTER TUBES (for a 30' truss; 3/12)	EA	2RT-30-312
RAFTER TUBES (for a 32' truss; 3/12)	EA	2RT-32-312
RAFTER TUBES (for a 34' truss; 3/12)	EA	2RT-34-312
RAFTER TUBES (for a 36' truss; 3/12)	EA	2RT-36-312
RAFTER TUBES (for a 38' truss; 3/12)	EA	2RT-38-312
RAFTER TUBES (for a 40' truss; 3/12)	EA	2RT-40-312
RAFTER TUBES also available for 2/12 pitch	EA	2RT-xx-212
RAFTER TUBES also available for 4/12 pitch	EA	2RT-xx-412
RAFTER TUBES also available for 5/12 pitch	EA	2RT-xx-512
RAFTER TUBES also available for 6/12 pitch	EA	2RT-xx-612
RAFTER TUBES Custom Length (specify exact length)	EA	2RT-2x3



Sub-Components

LEGS CUT-TO-LENGTH (2" x 3")

<u>Description</u>	<u>U/M</u>	<u>Part #</u>
For eave height = 7' (actual length = 61-1/2")	EA	2L-2X3-7.
For eave height = 7½' (actual length = 67-1/2")	EA	2L-2X3-7.5
For eave height = 8' (actual length = 73-1/2")	EA	2L-2X3-8
For eave height = 8½' (actual length = 79-1/2")	EA	2L-2X3-8.5
For eave height = 9' (actual length = 85-1/2")	EA	2L-2X3-9
For eave height = 9½' (actual length = 91-1/2")	EA	2L-2X3-9.5
For eave height = 10' (actual length = 97-1/2")	EA	2L-2X3-10
For eave height = 10½' (actual length = 103-1/2")	EA	2L-2X3-10.5
For eave height = 11' (actual length = 109-1/2")	EA	2L-2X3-11
For eave height = 11½' (actual length = 115-1/2")	EA	2L-2X3-11.5
For eave height = 12' (actual length = 121-1/2")	EA	2L-2X3-12
For eave height = 12½' (actual length = 127-1/2")	EA	2L-2X3-12.5
For eave height = 13' (actual length = 133-1/2")	EA	2L-2X3-13
For eave height = 13½' (actual length = 139-1/2")	EA	2L-2X3-13.5
For eave height = 14' (actual length = 145-1/2")	EA	2L-2X3-14
For custom length (specify exact length on order)	EA	2L-2X3

LEGS CUT-TO-LENGTH (2" x 2")

<u>Description</u>	<u>U/M</u>	<u>Part #</u>
For gable height up to 8' (piece length = 8')	EA	2L-2X2-8
For gable height up to 9' (piece length = 9')	EA	2L-2X2-9
For gable height up to 10' (piece length = 10')	EA	2L-2X2-10
For gable height up to 11' (piece length = 11')	EA	2L-2X2-11
For gable height up to 12' (piece length = 12')	EA	2L-2X2-12
For gable height up to 13' (piece length = 13')	EA	2L-2X2-13
For gable height up to 14' (piece length = 14')	EA	2L-2X2-14
For gable height up to 15' (piece length = 15')	EA	2L-2X2-15
For gable height up to 16' (piece length = 16')	EA	2L-2X2-16
For gable height up to 17' (piece length = 17')	EA	2L-2X2-17
For gable height up to 18' (piece length = 18')	EA	2L-2X2-18
For gable height up to 19' (piece length = 19')	EA	2L-2X2-19
For gable height up to 20' (piece length = 20')	EA	2L-2X2-20
For custom length (specify exact length on order)	EA	2L-2X2



METAL PRODUCTS
(800) 705-4550

Hat Channel

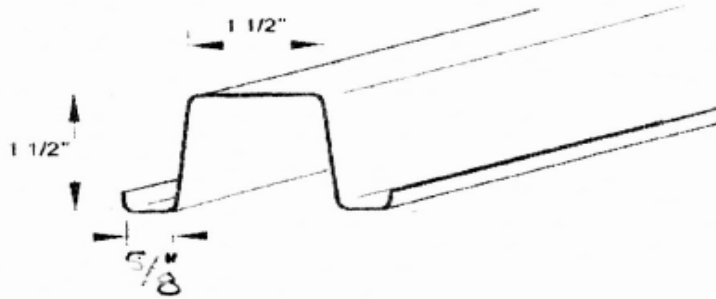
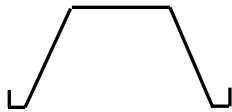

Description

- 1-1/2" hat channel 18 GA
- 1-1/2" X 58" hat channel purlin 18 GA (for 5' oc)
- 1-1/2" X 52" hat channel purlin 18 GA (for 4.5' oc)
- 1-1/2" X 46" hat channel purlin 18 GA (for 4' oc)
- 1-1/2" X 34" hat channel purlin 18 GA (for 3' oc)
- Hat channel double purlin bracket
- Hat channel single purlin bracket
- FRAMING SCREWS (250/bag)

U/M

- LF
- EA
- EA
- EA
- EA
- EA
- EA
- PKG

Part #

- 2HC-1.5
- 2HC-1.5-58
- 2HC-1.5-58
- 2HC-1.5-58
- 2HC-1.5-58
- 2HB-HC2
- 2HB-HC1
- SP-G-12-.75 (bag)



METAL PRODUCTS
(800) 705-4550

Galvanized C-Purlins

	Height	Width	20 GA AFP Part#	18 GA AFP Part#	16 GA AFP Part#	14 GA AFP Part#	12 GA AFP Part#
1-1/4"	2.5	1.25	2TPC-20-2.5x1.25	2TPC-18-2.5x1.25	2TPC-16-2.5x1.25	2TPC-14-2.5x1.25	not available
	3.5	1.25	2TPC-20-3.5x1.25	2TPC-18-3.5x1.25	2TPC-16-3.5x1.25	2TPC-14-3.5x1.25	not available
	3.625	1.25	2TPC-20-3.625x1.25	2TPC-18-3.625x1.25	2TPC-16-3.625x1.25	2TPC-14-3.625x1.25	not available
	4	1.25	2TPC-20-4x1.25	2TPC-18-4x1.25	2TPC-16-4x1.25	2TPC-14-4x1.25	not available
	5.5	1.25	2TPC-20-5.5x1.25	2TPC-18-5.5x1.25	2TPC-16-5.5x1.25	2TPC-14-5.5x1.25	not available
	6	1.25	2TPC-20-6x1.25	2TPC-18-6x1.25	2TPC-16-6x1.25	2TPC-14-6x1.25	not available
1-1/4"	8	1.25	2TPC-20-8x1.25	2TPC-18-8x1.25	2TPC-16-8x1.25	2TPC-14-8x1.25	not available
1-3/8"	2.5	1.375	2TPC-20-2.5x1.375	2TPC-18-2.5x1.375	2TPC-16-2.5x1.375	2TPC-14-2.5x1.375	not available
	3.5	1.375	2TPC-20-3.5x1.375	2TPC-18-3.5x1.375	2TPC-16-3.5x1.375	2TPC-14-3.5x1.375	not available
	3.625	1.375	2TPC-20-3.625x1.375	2TPC-18-3.625x1.375	2TPC-16-3.625x1.375	2TPC-14-3.625x1.375	not available
	4	1.375	2TPC-20-4x1.375	2TPC-18-4x1.375	2TPC-16-4x1.375	2TPC-14-4x1.375	not available
	5.5	1.375	2TPC-20-5.5x1.375	2TPC-18-5.5x1.375	2TPC-16-5.5x1.375	2TPC-14-5.5x1.375	not available
	6	1.375	2TPC-20-6x1.375	2TPC-18-6x1.375	2TPC-16-6x1.375	2TPC-14-6x1.375	not available
1-3/8"	8	1.375	2TPC-20-8x1.375	2TPC-18-8x1.375	2TPC-16-8x1.375	2TPC-14-8x1.375	not available
1-5/8"	2.5	1.625	2TPC-20-2.5x1.625	2TPC-18-2.5x1.625	2TPC-16-2.5x1.625	2TPC-14-2.5x1.625	not available
	3.5	1.625	2TPC-20-3.5x1.625	2TPC-18-3.5x1.625	2TPC-16-3.5x1.625	2TPC-14-3.5x1.625	2TPC-12-3.5x1.625
	3.625	1.625	2TPC-20-3.625x1.625	2TPC-18-3.625x1.625	2TPC-16-3.625x1.625	2TPC-14-3.625x1.625	2TPC-12-3.625x1.625
	4	1.625	2TPC-20-4x1.625	2TPC-18-4x1.625	2TPC-16-4x1.625	2TPC-14-4x1.625	2TPC-12-4x1.625
	5.5	1.625	2TPC-20-5.5x1.625	2TPC-18-5.5x1.625	2TPC-16-5.5x1.625	2TPC-14-5.5x1.625	not available
	6	1.625	2TPC-20-6x1.625	2TPC-18-6x1.625	2TPC-16-6x1.625	2TPC-14-6x1.625	2TPC-12-6x1.625
	8	1.625	2TPC-20-8x1.625	2TPC-18-8x1.625	2TPC-16-8x1.625	2TPC-14-8x1.625	2TPC-12-8x1.625
	10	1.625	2TPC-20-10x1.625	2TPC-18-10x1.625	2TPC-16-10x1.625	2TPC-14-10x1.625	2TPC-12-10x1.625
1-5/8"	12	1.625	2TPC-20-12x1.625	2TPC-18-12x1.625	2TPC-16-12x1.625	2TPC-14-12x1.625	2TPC-12-12x1.625
2"	3.625	2	2TPC-20-3.625x2	2TPC-18-3.625x2	2TPC-16-3.625x2	2TPC-14-3.625x2	2TPC-12-3.625x2
	4	2	2TPC-20-4x2	2TPC-18-4x2	2TPC-16-4x2	2TPC-14-4x2	2TPC-12-4x2
	6	2	2TPC-20-6x2	2TPC-18-6x2	2TPC-16-6x2	2TPC-14-6x2	2TPC-12-6x2
	8	2	2TPC-20-8x2	2TPC-18-8x2	2TPC-16-8x2	2TPC-14-8x2	2TPC-12-8x2
	10	2	2TPC-20-10x2	2TPC-18-10x2	2TPC-16-10x2	2TPC-14-10x2	2TPC-12-10x2
	12	2	2TPC-20-12x2	2TPC-18-12x2	2TPC-16-12x2	2TPC-14-12x2	2TPC-12-12x2
2"	14	2	2TPC-20-14x2	2TPC-18-14x2	2TPC-16-14x2	2TPC-14-14x2	2TPC-12-14x2
2-1/2"	3.625	2.5	2TPC-20-3.625x2.5	2TPC-18-3.625x2.5	2TPC-16-3.625x2.5	2TPC-14-3.625x2.5	2TPC-12-3.625x2.5
	4	2.5	2TPC-20-4x2.5	2TPC-18-4x2.5	2TPC-16-4x2.5	2TPC-14-4x2.5	2TPC-12-4x2.5
	6	2.5	2TPC-20-6x2.5	2TPC-18-6x2.5	2TPC-16-6x2.5	2TPC-14-6x2.5	2TPC-12-6x2.5
	8	2.5	2TPC-20-8x2.5	2TPC-18-8x2.5	2TPC-16-8x2.5	2TPC-14-8x2.5	2TPC-12-8x2.5
	10	2.5	2TPC-20-10x2.5	2TPC-18-10x2.5	2TPC-16-10x2.5	2TPC-14-10x2.5	2TPC-12-10x2.5
	12	2.5	2TPC-20-12x2.5	2TPC-18-12x2.5	2TPC-16-12x2.5	2TPC-14-12x2.5	2TPC-12-12x2.5
2-1/2"	14	2.5	2TPC-20-14x2.5	2TPC-18-14x2.5	2TPC-16-14x2.5	2TPC-14-14x2.5	2TPC-12-14x2.5
3"	3.625	3	2TPC-20-3.625x3	2TPC-18-3.625x3	2TPC-16-3.625x3	2TPC-14-3.625x3	2TPC-12-3.625x3
	4	3	2TPC-20-4x3	2TPC-18-4x3	2TPC-16-4x3	2TPC-14-4x3	2TPC-12-4x3
	6	3	2TPC-20-6x3	2TPC-18-6x3	2TPC-16-6x3	2TPC-14-6x3	2TPC-12-6x3
	8	3	2TPC-20-8x3	2TPC-18-8x3	2TPC-16-8x3	2TPC-14-8x3	2TPC-12-8x3
	10	3	2TPC-20-10x3	2TPC-18-10x3	2TPC-16-10x3	2TPC-14-10x3	2TPC-12-10x3
	12	3	2TPC-20-12x3	2TPC-18-12x3	2TPC-16-12x3	2TPC-14-12x3	2TPC-12-12x3
3"	14	3	2TPC-20-14x3	2TPC-18-14x3	2TPC-16-14x3	2TPC-14-14x3	2TPC-12-14x3



METAL PRODUCTS
(800) 705-4550

Galvanized Track

	Height	Width	20 GA AFP Part#	18 GA AFP Part#	16 GA AFP Part#	14 GA AFP Part#	12 GA AFP Part#
1-1/4"	2.5	1.25	2TT-20-2.5x1.25	2TT-18-2.5x1.25	2TT-16-2.5x1.25	2TT-14-2.5x1.25	2TT-12-2.5x1.25
	3.5	1.25	2TT-20-3.5x1.25	2TT-18-3.5x1.25	2TT-16-3.5x1.25	2TT-14-3.5x1.25	2TT-12-3.5x1.25
	3.625	1.25	2TT-20-3.625x1.25	2TT-18-3.625x1.25	2TT-16-3.625x1.25	2TT-14-3.625x1.25	2TT-12-3.625x1.25
	4	1.25	2TT-20-4x1.25	2TT-18-4x1.25	2TT-16-4x1.25	2TT-14-4x1.25	2TT-12-4x1.25
	5.5	1.25	2TT-20-5.5x1.25	2TT-18-5.5x1.25	2TT-16-5.5x1.25	2TT-14-5.5x1.25	2TT-12-5.5x1.25
	6	1.25	2TT-20-6x1.25	2TT-18-6x1.25	2TT-16-6x1.25	2TT-14-6x1.25	2TT-12-6x1.25
	8	1.25	2TT-20-8x1.25	2TT-18-8x1.25	2TT-16-8x1.25	2TT-14-8x1.25	2TT-12-8x1.25
1-1/4"	10	1.25	2TT-20-10x1.25	2TT-18-10x1.25	2TT-16-10x1.25	2TT-14-10x1.25	2TT-12-10x1.25
	12	1.25	2TT-20-12x1.25	2TT-18-12x1.25	2TT-16-12x1.25	2TT-14-12x1.25	2TT-12-12x1.25
	14	1.25	2TT-20-14x1.25	2TT-18-14x1.25	2TT-16-14x1.25	2TT-14-14x1.25	2TT-12-14x1.25
1-1/2"	2.5	1.5	2TT-20-2.5x1.5	2TT-18-2.5x1.5	2TT-16-2.5x1.5	2TT-14-2.5x1.5	2TT-12-2.5x1.5
	3.5	1.5	2TT-20-3.5x1.5	2TT-18-3.5x1.5	2TT-16-3.5x1.5	2TT-14-3.5x1.5	2TT-12-3.5x1.5
	3.625	1.5	2TT-20-3.625x1.5	2TT-18-3.625x1.5	2TT-16-3.625x1.5	2TT-14-3.625x1.5	2TT-12-3.625x1.5
	4	1.5	2TT-20-4x1.5	2TT-18-4x1.5	2TT-16-4x1.5	2TT-14-4x1.5	2TT-12-4x1.5
	5.5	1.5	2TT-20-5.5x1.5	2TT-18-5.5x1.5	2TT-16-5.5x1.5	2TT-14-5.5x1.5	2TT-12-5.5x1.5
	6	1.5	2TT-20-6x1.5	2TT-18-6x1.5	2TT-16-6x1.5	2TT-14-6x1.5	2TT-12-6x1.5
	8	1.5	2TT-20-8x1.5	2TT-18-8x1.5	2TT-16-8x1.5	2TT-14-8x1.5	2TT-12-8x1.5
	10	1.5	2TT-20-10x1.5	2TT-18-10x1.5	2TT-16-10x1.5	2TT-14-10x1.5	2TT-12-10x1.5
	12	1.5	2TT-20-12x1.5	2TT-18-12x1.5	2TT-16-12x1.5	2TT-14-12x1.5	2TT-12-12x1.5
2"	14	1.5	2TT-20-14x1.5	2TT-18-14x1.5	2TT-16-14x1.5	2TT-14-14x1.5	2TT-12-14x1.5
	3.625	2"	2TT-20-3.625x2	2TT-18-3.625x2	2TT-16-3.625x2	2TT-14-3.625x2	2TT-12-3.625x2
	4	2"	2TT-20-4x2	2TT-18-4x2	2TT-16-4x2	2TT-14-4x2	2TT-12-4x2
	6	2"	2TT-20-6x2	2TT-18-6x2	2TT-16-6x2	2TT-14-6x2	2TT-12-6x2
	8	2"	2TT-20-8x2	2TT-18-8x2	2TT-16-8x2	2TT-14-8x2	2TT-12-8x2
	10	2"	2TT-20-10x2	2TT-18-10x2	2TT-16-10x2	2TT-14-10x2	2TT-12-10x2
	12	2"	2TT-20-12x2	2TT-18-12x2	2TT-16-12x2	2TT-14-12x2	2TT-12-12x2
2"	14	2"	2TT-20-14x2	2TT-18-14x2	2TT-16-14x2	2TT-14-14x2	2TT-12-14x2
2-1/2"	3.5	2.5	2TT-20-3.5x2.5	2TT-18-3.5x2.5	2TT-16-3.5x2.5	2TT-14-3.5x2.5	2TT-12-3.5x2.5
	3.625	2.5	2TT-20-3.625x2.5	2TT-18-3.625x2.5	2TT-16-3.625x2.5	2TT-14-3.625x2.5	2TT-12-3.625x2.5
	4	2.5	2TT-20-4x2.5	2TT-18-4x2.5	2TT-16-4x2.5	2TT-14-4x2.5	2TT-12-4x2.5
	6	2.5	2TT-20-6x2.5	2TT-18-6x2.5	2TT-16-6x2.5	2TT-14-6x2.5	2TT-12-6x2.5
	8	2.5	2TT-20-8x2.5	2TT-18-8x2.5	2TT-16-8x2.5	2TT-14-8x2.5	2TT-12-8x2.5
	10	2.5	2TT-20-10x2.5	2TT-18-10x2.5	2TT-16-10x2.5	2TT-14-10x2.5	2TT-12-10x2.5
	12	2.5	2TT-20-12x2.5	2TT-18-12x2.5	2TT-16-12x2.5	2TT-14-12x2.5	2TT-12-12x2.5
2-1/2"	14	2.5	2TT-20-14x2.5	2TT-18-14x2.5	2TT-16-14x2.5	2TT-14-14x2.5	2TT-12-14x2.5
3"	3.625	3"	2TT-20-3.625x3	2TT-18-3.625x3	2TT-16-3.625x3	2TT-14-3.625x3	2TT-12-3.625x3
	4	3"	2TT-20-4x3	2TT-18-4x3	2TT-16-4x3	2TT-14-4x3	2TT-12-4x3
	6	3"	2TT-20-6x3	2TT-18-6x3	2TT-16-6x3	2TT-14-6x3	2TT-12-6x3
	8	3"	2TT-20-8x3	2TT-18-8x3	2TT-16-8x3	2TT-14-8x3	2TT-12-8x3
	10	3"	2TT-20-10x3	2TT-18-10x3	2TT-16-10x3	2TT-14-10x3	2TT-12-10x3
	12	3"	2TT-20-12x3	2TT-18-12x3	2TT-16-12x3	2TT-14-12x3	2TT-12-12x3
3"	14	3"	2TT-20-14x3	2TT-18-14x3	2TT-16-14x3	2TT-14-14x3	2TT-12-14x3

- 1) There is a \$100.00 set-up charge for orders of less than 1,000' per item.
- 2) Structural Steel Framing Products are non-returnable and non-cancelable products.
- 3) All manufactured UNPUNCHED.



METAL PRODUCTS
(800) 705-4550

Brackets

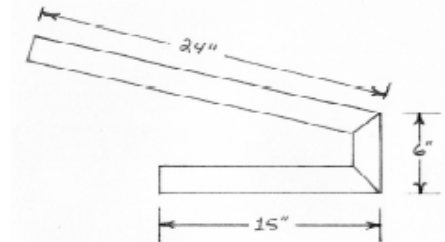
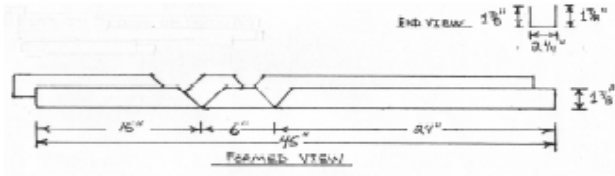

Eave Overhang Bracket, 14 gauge HDG
2HB-EOB

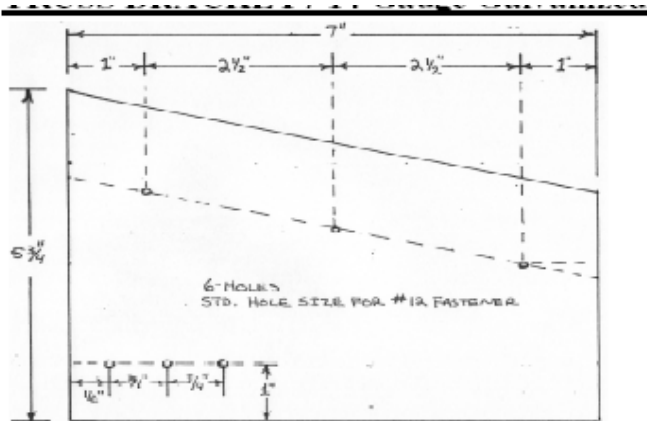

Angled Flat Truss Bracket
Six Holes
5-3/4" X 7" X 14
gauge HDG
2HB-AB-5.75X7

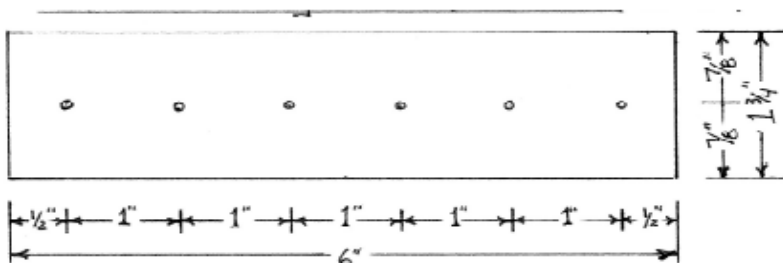

Flat Bracket
Six Holes
1-3/4" X 6" X 14
gauge HDG
2HB-FB-1.75X6



Brackets

AWNING BRACKET / 14 GAUGE GALVANIZED

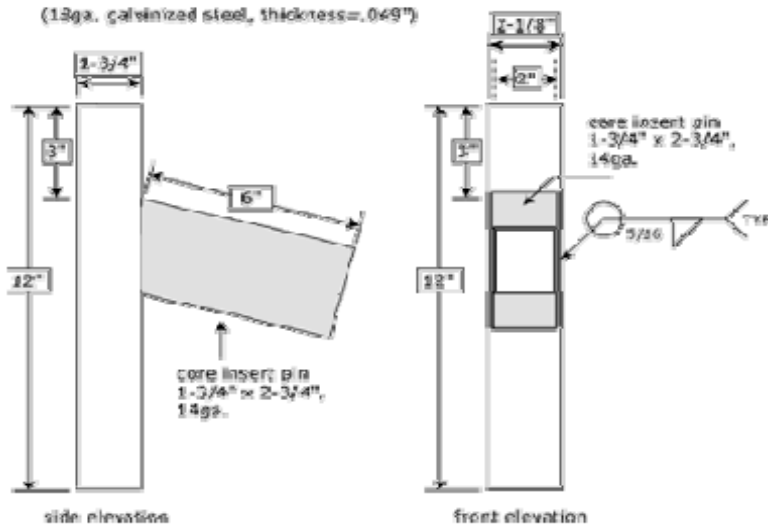

Step Down
Awning Bracket

2HB-ARB

SQUARE CORNER BRACKET / 14 GAUGE GALVANIZED

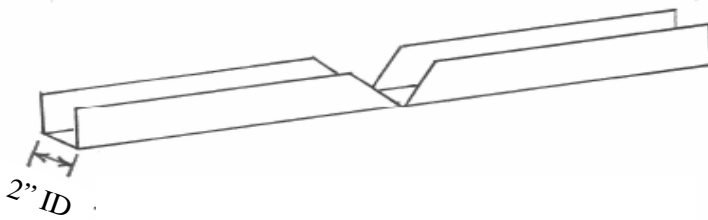

Square Corner
Bracket

2HB-CBS



Brackets

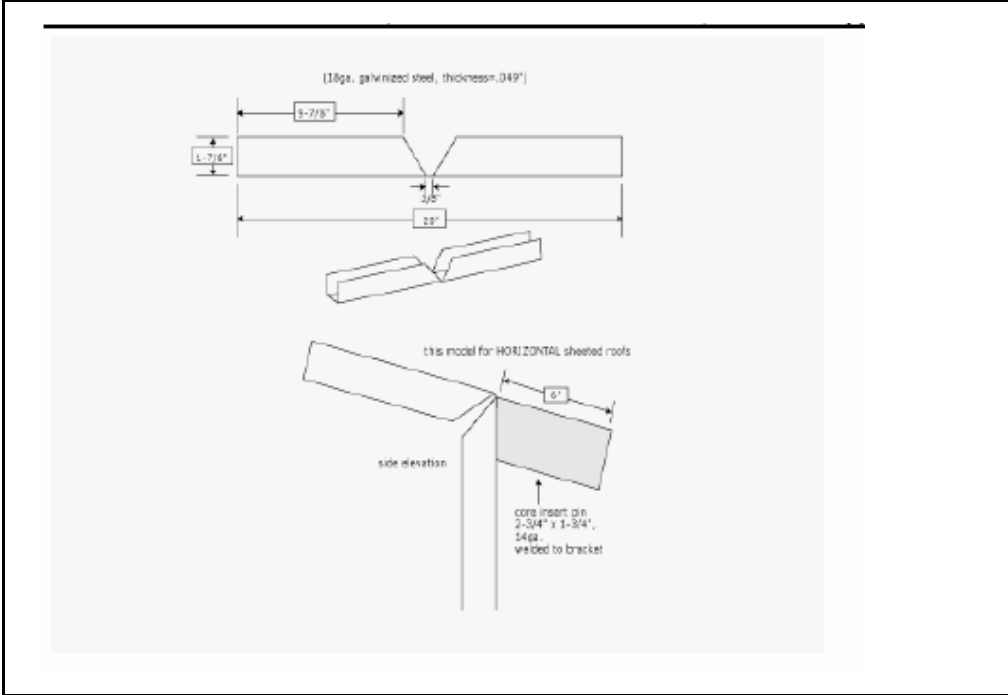

**Awning Bracket
 (continuous
 roofline)**

2HB-ACB

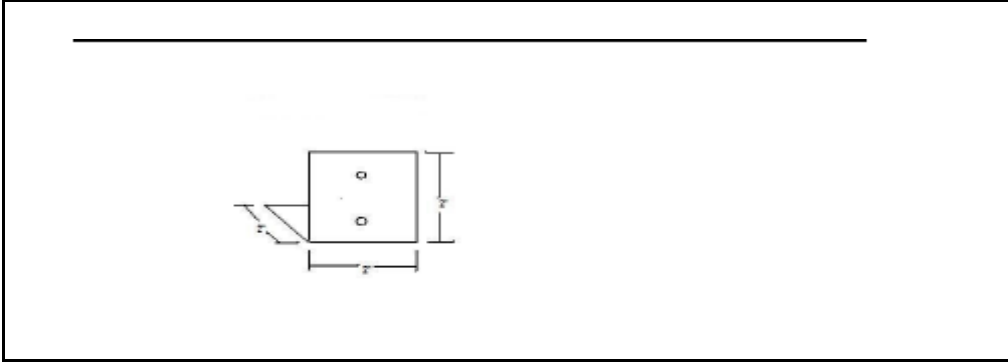

**Angle Bracket
 Four Holes
 2" X 2" X 2"
 X 14 gauge HDG**

2HB-AB-2X2X2,4H

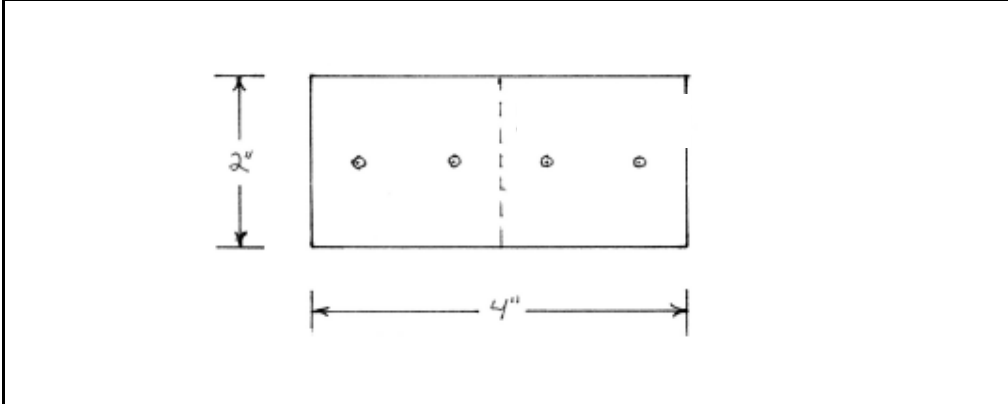

**Flat Bracket
 Four Holes
 2" X 4" X 14
 gauge HDG**

2HB-FB-2X4



METAL PRODUCTS
(800) 705-4550

Brackets

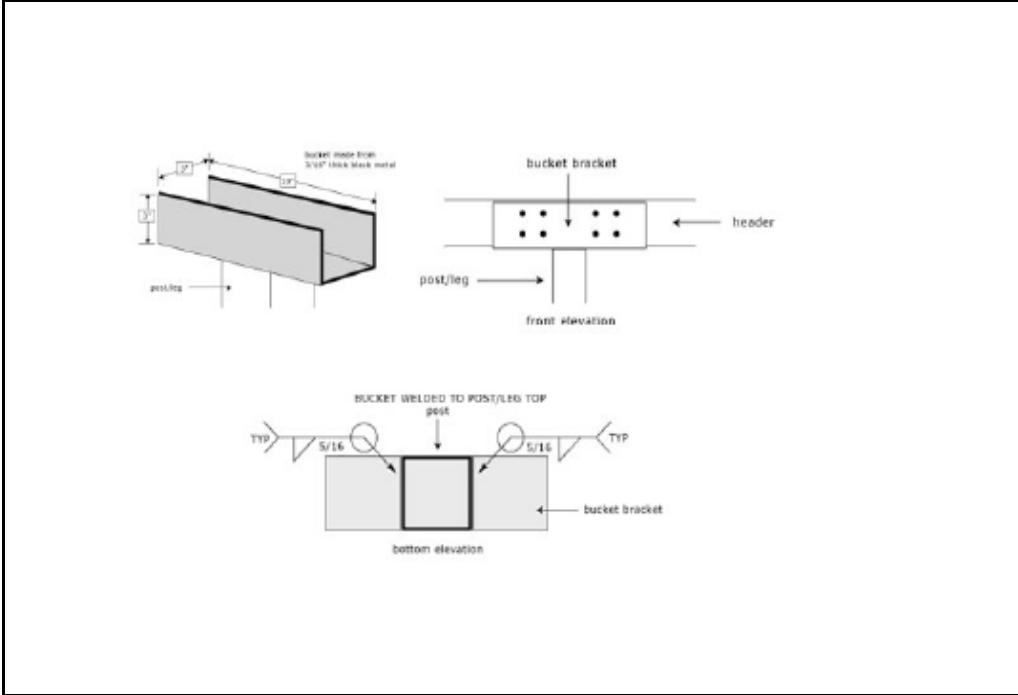

**Bucket Bracket
2HB-BB**

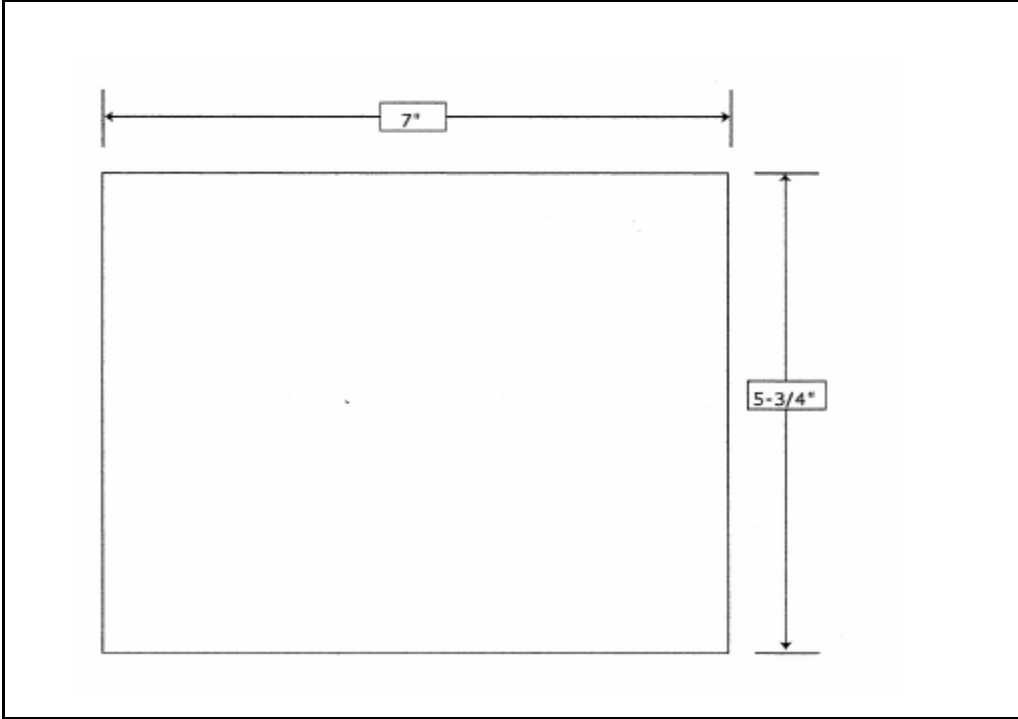

**Flat Bracket
No Holes
5-3/4" X 7" X
14 gauge HDG
2HB-FB-5.75X7**